



vänEE 70E ERV-R / Venmar AVS S10 ERV-R

Part no. 41801*

Low speed: 50 CFM (0.2 in. w.g.), selectable 65 CFM

High speed: 102 CFM (0.4 in. w.g.), selectable 85 CFM

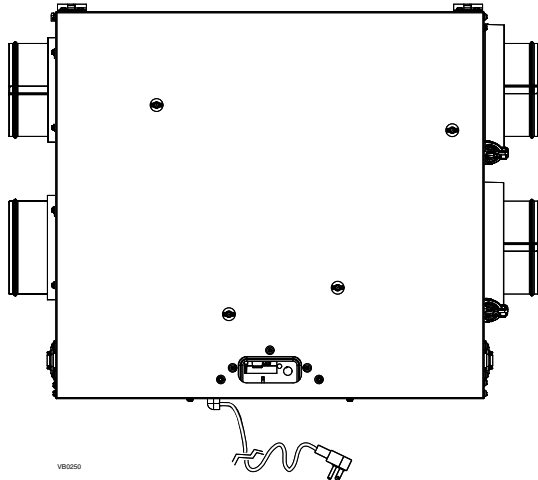

* This unit is the equivalent of 41800 (same parts and same performance) except for its reversed cold side and warm side ports configuration.

CONSTRUCTION

- Reversed cold side and warm side ports for a better installation flexibility (see **Figure 1** on page 2)
- Galvanized steel housing and door
- One-piece molded insulation shell, (expanded polystyrene; UL 94 HF-1 certified)
- Galvanized steel 5" diameter ports*
- Steel door hinges and latches
- Cold side ports with plastic ring; allow vapor barrier sealing
- No drain required
- Included installation brackets

*All units ports were created to be connected to ducts having a minimum of 5" diameter, but if need be, they can be connected to bigger sized ducts by using an appropriate transition (e.g.: 5" diameter to 6" diameter transition).

MOTORS

- Two high reliability, external rotor PSC motors, totally enclosed and thermally protected
- Backward blowers, can support high static pressure environment

FILTERS

- Two washable 20 ppi reticulated polyester urethane foam filters, UL 900 class 2 certified
- Optional MERV 8 filter kit, part no. V21030 (additional 0.1 in. w.g. static pressure to be considered) (sold separately)

ERV CORE

- Crossflow aluminum-polymerized paper core, UL723 certified
- Hydroscopic polymer exchange water by direct vapor transfer using molecular transport without the need of condensation
- Constructed of alternate layers of corrugated aluminum material and polymeric bactericide dessiccant impregnated media; will not promote growth of mold or bacteria
- Unique rectangular flute design to provide very low pressure drop values

ENERGY RECOVERY VENTILATOR

Controls

- Integrated push-button control for Low or High speed operation.
- For a complete list of optional main and auxiliary controls available, refer to the **Wall Control Compatibility Chart** on last pages of wall controls specification sheet, available at Broan-NuTone.ca.
- For more details about controls, refer to the **Main and auxiliary wall controls** user guide, also available at www.vanee.ca.
- Removable terminal block included for quicker low voltage control connections.
- LED indicator shows operating modes and error codes.
- Unit must be permanently energized, no control should be installed on power supply of unit.

Air Flow

- Pressure taps and balancing chart to allow easier balancing of the unit
- Integrated balancing/backdraft dampers in cold supply and cold exhaust ports

Defrost Cycles

- Choice of regular or extended defrost cycles, according to climatic conditions
- To set extended defrost cycles, refer to unit installation manual

REGULAR DEFROST CYCLES			
OUTSIDE TEMPERATURE*		DEFROST IN MINUTES / AIR EXCHANGE IN MINUTES	
°C	°F	LOW SPEED	HIGH SPEED
WARMER THAN -10	WARMER THAN 14	NO DEFROST	NO DEFROST
FROM -10 TO -15	FROM 14 TO 5	6/40	9/40
FROM -15 TO -27	FROM 5 TO -17	6/20	9/20
-27 AND LESS	-17 AND LESS	8/12	11/12

* Outside temperature is read by a thermistor located inside the unit, next to fresh air from outside port.

Warranty

The 41801 is protected by a 5-year warranty on parts only, with the original proof of purchase.

Requirements and standards

- **HVI certified**
- Certified to UL 1812 safety standard for ducted heat recovery ventilators
- Certified to CSA C22.2 No. 113 safety standard for fans and ventilators
- Complies with CSA C444 requirements regulating the installation of Energy Recovery Ventilators



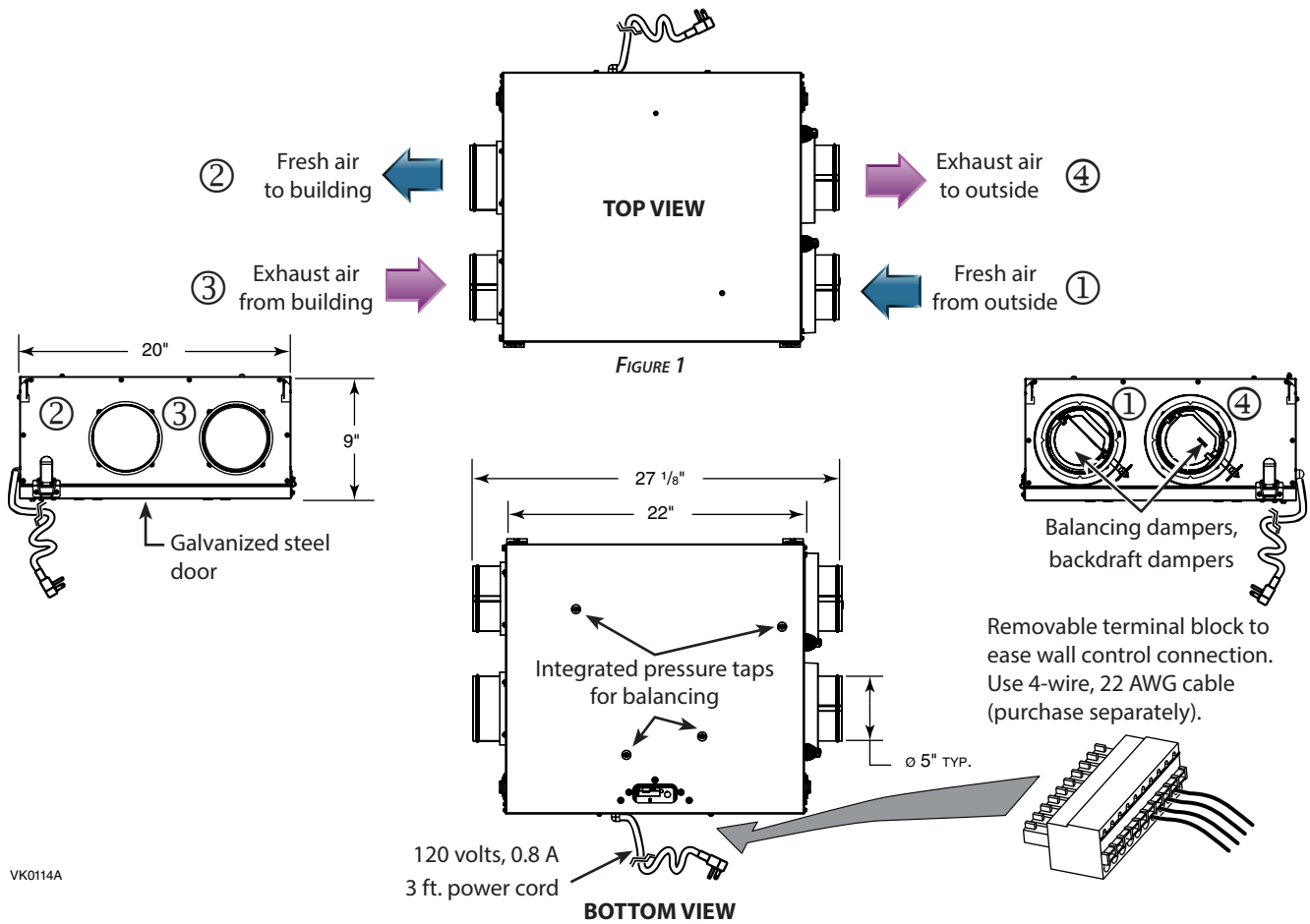

VK0114A

HORIZONTAL INSTALLATION ONLY

Allow 24" x 30" minimum for access door.

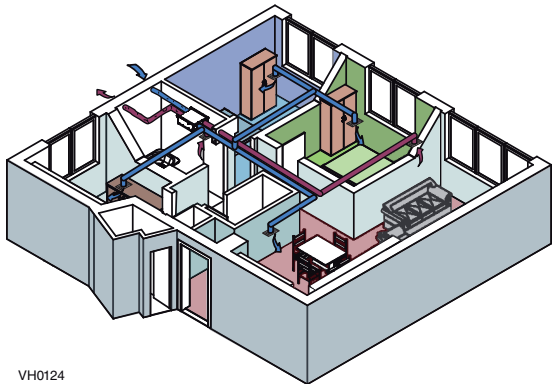

VH0124

Example of a fully ducted installation

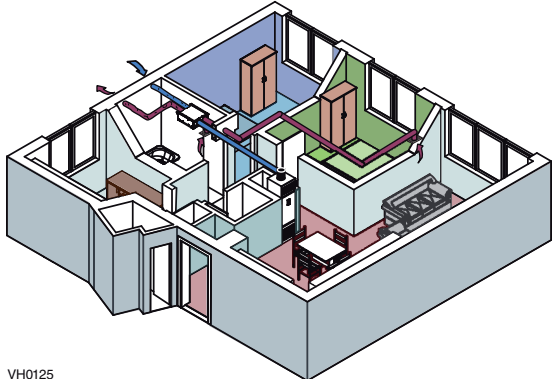

VH0125

Example of a central draw point installation

UNIQUE 3 EASY STEPS FOR CEILING INSTALLATION

- 1 Mount brackets to ceiling.
- 2 Bend integrated hooks (2 on the same side) and hang the unit.
 - 2 x
 - Integrated dampening device to prevent vibration transmission
- 3 Clip the other side of the unit to the brackets.
 - 2 x
 - VO0279

Simplified Installation (connection to a forced air system)

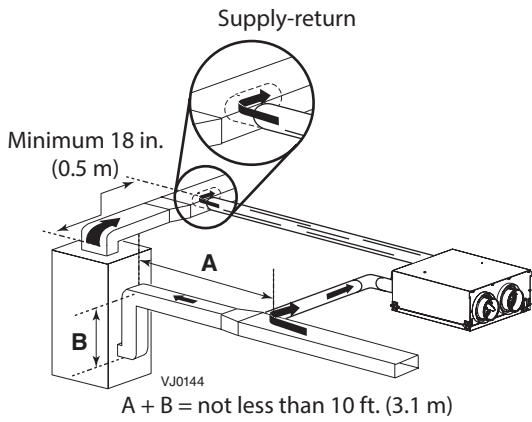

NOT Return-return!

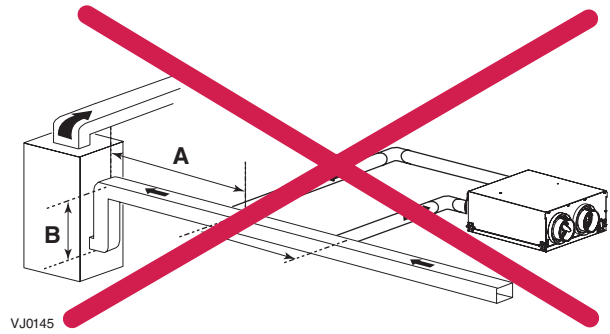

VENTILATION PERFORMANCE

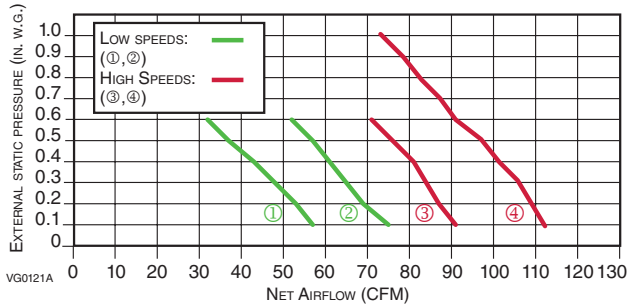

NOTE: Low speed ① and high speed ④ are factory set, low speed ② and high speed ③ are selectable. Curves are not certified by HVI.

ENERGY PERFORMANCE

SUPPLY TEMPERATURE		NET AIR FLOW			POWER CONSUMED WATTS	SENSIBLE RECOVERY EFFICIENCY	ADJUSTED SENSIBLE RECOVERY EFFICIENCY	APPARENT SENSIBLE EFFECTIVENESS*	LATENT RECOVERY/MOISTURE TRANSFER
°C	°F	L/s	CFM	M ³ /H					
HEATING									
0	32	23	49	82	40	66%	72%	73%	0.51
0	32	30	64	108	50	65%	70%	71%	0.47
0	32	47	100	169	85	60%	66%	67%	0.41
-10	14	24	51	86	40	65%	69%	71%	0.53
-25	-13	24	51	86	36	46%	47%	75%	0.36
COOLING									
35	95	22	47	79	40	50%	53%	66%	0.50
35	95	30	64	108	50	47%	50%	63%	0.45
35	95	38	81	137	60	44%	47%	58%	0.41

*Data not certified by HVI.
NOTE: All specifications are subject to change without notice.

Ext. Static Pressure (Pa)	Ext. Static Pressure (in. wg)	Net Supply Airflow (L/s)	Net Supply Airflow (cfm)	Gross Airflow Supply (L/s)	Gross Airflow Supply (cfm)	Gross Airflow Exhaust (L/s)	Gross Airflow Exhaust (cfm)
25	0.1	53	112	55	117	56	119
50	0.2	51	108	53	112	54	114
75	0.3	50	106	51	108	52	110
100	0.4	48	102	49	104	50	106
125	0.5	46	97	47	100	47	100
150	0.6	43	91	45	95	45	95
175	0.7	41	87	43	91	43	91
200	0.8	39	83	41	87	40	85
225	0.9	37	78	38	81	38	81
250	1.0	35	74	36	76	35	74

Coldshield™ Protection

ERV unit is equipped with an electronic supplemental protection to stop air distribution in dwelling if air distribution temperature drops below freezing point, due to abnormal conditions.

ERV UNIT MODES BASED ON AIR DISTRIBUTION TEMPERATURE

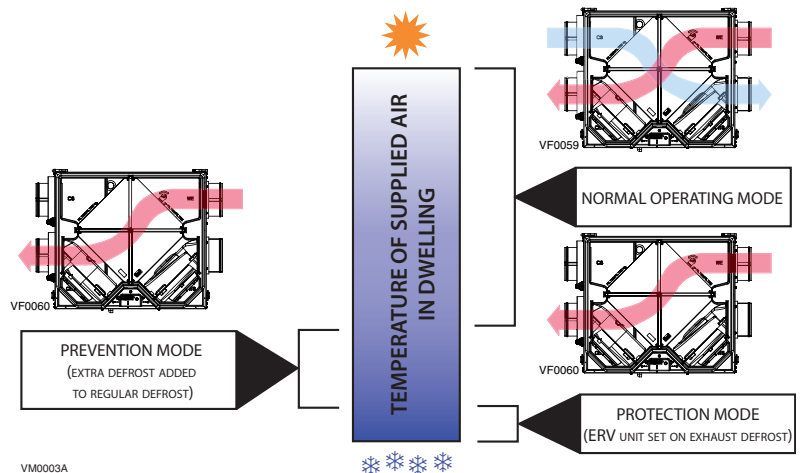

VÄNÉE 70E ERV-R / VENMAR AVS S10 ERV-R ARCHITECTURAL SPECIFICATIONS

AIRFLOW

- High static pressure backward blowers shall perform a minimum of 74 CFM @ 1.0 in. w.g.
- Optional high speed: 85 CFM
- Optional low speed: 65 CFM

CONSTRUCTION

- Cold side and warm side must be reversed (compared to standard units) for better installation flexibility (see **Figure 1** on page 2). This symmetrical configuration simplifies the installations in buildings having back-to-back dwellings
- Housing and door shall be made of galvanized steel
- Insulation shall be made of one-piece molded expanded polystyrene, UL 94 HF-1 certified
- 5" diameter ports shall be made of galvanized steel
- Door hinges and latches shall be made of steel
- Cold side ports shall have plastic ring to allow vapor barrier sealing
- Unit construction and components shall be UL and CSA certified
- Unit shall operate all year long without drain
- Weight shall not exceed 32 lb.
- Fresh air from outside and Exhaust air to outside ports shall be located on same side
- Backdraft dampers shall be integrated in cold supply and cold exhaust ports
- ERV unit shall be HVI certified

MOTORS

- Unit shall have two high reliability, external rotor PSC motors, totally enclosed and thermally protected
- The backward blowers shall support high static pressure environment
- The insulation class shall be B

FILTERS

- ERV unit shall have two washable 20 ppi reticulated polyester urethane foam filters, UL 900 class 2 certified
- Optional MERV 8 filter kit, part no. V21030

ERV CORE

- The ERV core shall be a crossflow aluminum-polymerized paper core, UL723 certified
- Hydroscopic polymer exchange water by direct vapor transfer shall use molecular transport without the need of condensation
- The ERV core shall be constructed of alternate layers of corrugated aluminum material and polymeric bactericide dessiccant impregnated media; and shall not promote growth of mold or bacteria
- The ERV core design shall be made of rectangular flutes to provide very low pressure drop values

Controls

- Unit shall be equipped with an integrated push-button control for Low or High speed operation
- Choice of low voltage main controls (not included) shall be energized by ERV unit
- Optional low voltage auxiliary controls (not included) shall be energized by ERV unit
- Removable terminal block shall be included for quicker low voltage control connections
- A LED indicator shall indicate operating modes as well as error codes
- ERV unit shall be permanently energized, no control shall be installed on power supply of unit

Air Flow Balancing

- Unit door shall be equipped with pressure taps as well as a balancing chart to allow verification of balancing of the ERV unit
- Balancing dampers shall be integrated in cold supply and cold exhaust ports

Defrost Cycles

- Unit operation shall include a choice of regular or extended defrost cycles, according to climatic conditions
- Unit shall be equipped with Coldshield™ protection to stop air supply in dwelling if air supply temperature drops below freezing point, due to abnormal conditions.

Acoustic Noise Power (not certified by HVI)

- The unit shall have a maximum acoustic noise power of 58.0 dBA on low speed at 0.1 in. w.g. and 67.8 dBA on high speed at 0.4 in. w.g., measured according to ISO 5136 Standard, at fresh air to building port.
- The unit shall have a maximum acoustic noise power of 49.4 dBA on low speed at 0.1 in. w.g. and 58.3 dBA on high speed at 0.4 in. w.g., measured according to ISO 5136 Standard, at exhaust air from building port.

Warranty

Unit shall be protected by a 5-year warranty on parts only, with the original proof of purchase.

Requirements and standards

- Shall be HVI certified as per CSA C439 Standards
- Shall be certified to UL 1812 safety standard for ducted heat recovery ventilators
- Shall be certified to CSA C22.2 No. 113 safety standard for fans and ventilators
- Shall comply with CSA C444 requirements regulating the installation of Energy Recovery Ventilators

Project:	REMARKS
Location:	
Part no.: 41801	
Qty.:	
Submitted by: _____ Date: _____	

