

USER AND INSTALLER MANUAL



VB0253

HRV CONSTRUCTO 1.5ES	46110
HRV CONSTRUCTO 2.0ES	47110
HRV SOLO 1.5ES	46720
HRV SOLO 2.0ES	47720
HRV NOVOFIT 1.5ES	46121
HRV NOVOFIT 2.0ES	47121



VB0254

100H	1601706
200H	1601708
NOVO+ 100H	1601717
NOVO+ 200H	1601719

READ AND SAVE THESE INSTRUCTIONS

RESIDENTIAL USE ONLY



7 72371 11856 0

Please take note that this manual uses the following symbols to emphasize particular information:

⚠ WARNING

Identifies an instruction which, if not followed, might cause serious personal injuries including possibility of death.

CAUTION

Denotes an instruction which, if not followed, may severely damage the unit and/or its components.

NOTE: Indicates supplementary information needed to fully complete an instruction.

LIMITATION

For residential (domestic) installation only. Installation work and electrical wiring must be done by a qualified person in accordance with all applicable codes and standards, including fire-rated construction codes and standards.

⚠ WARNING

TO REDUCE THE RISK OF FIRE, ELECTRIC SHOCK, OR INJURY TO PERSON(S) OBSERVE THE FOLLOWING:

1. Use this unit only in the manner intended by the manufacturer.
2. Before servicing or cleaning this unit, disconnect power cord from electrical outlet.
3. This unit is not designed to provide combustion and/or dilution air for fuel-burning appliances.
4. When cutting or drilling into a wall or ceiling, do not damage electrical wiring and other hidden utilities.
5. Do not use this unit with any solid-state speed control device other than those specified in section 7.2.
6. This unit must be grounded. The power supply cord has a 3-prong grounding plug for your personal safety. It must be plugged into a mating 3-prong grounding receptacle, grounded in accordance with the national electrical code and local codes and ordinances. Do not remove the ground prong. Do not use an extension cord.
7. Do not install in a cooking area or connect directly to any appliances.
8. Do not use to exhaust hazardous or explosive materials and vapors.
9. When performing installation, servicing or cleaning this unit, it is recommended to wear safety glasses and gloves.
10. When applicable local regulation comprises more restrictive installation and/or certification requirements, the aforementioned requirements prevail on those of this document and the installer agrees to conform to these at his own expense.
11. Due to the weight of the unit, two installers are recommended to perform installation.

CAUTION

1. To avoid prematurely clogged filters, turn the unit OFF during construction or renovation.
2. Please read specification label on product for further information and requirements.
3. Be sure to duct air outside – Do not intake/exhaust air into spaces within walls or ceiling or into attics, crawl spaces, or garage. Do not attempt to recover the exhaust air from a dryer or a range hood.
4. Intended for residential installation only in accordance with the requirements of NFPA 90B (for a unit installed in U.S.A.) or Part 9 of the National Building Code of Canada (for a unit installed in Canada).
5. Do not run any air ducts directly above or within 2 ft (0.61 m) of a furnace or its supply plenum, boiler, or other heat producing appliance. If a duct has to be connected to the furnace return plenum, it must be connected 10' (3.1 m) away from plenum's connection to the furnace.
6. The ductwork is intended to be installed in compliance with all applicable local and national codes.
7. When leaving the house for a long period of time (more than two weeks), a responsible person should regularly check if the unit operates adequately.
8. If the ductwork passes through an unconditioned space (e.g.: attic), the unit must operate continuously except when performing maintenance and/or repair. Also, the ambient temperature of the house should never drop below 18°C (65°F).
9. At least once a year, the unit mechanical and electronic parts should be inspected by qualified service personnel.
10. Do not use your unit during construction or renovation of your house or when sanding drywall. Certain types of dust and vapors may damage your system.
11. Make sure at all times that the outside intake and exhaust hoods are free from any snow during the winter season. It is important to check your unit during a big snow storm, so it doesn't draw in any snow. If this is the case, please turn the unit OFF for a few hours.
12. Since the electronic control system of the unit uses a microprocessor, it may not operate correctly because of external noise or very short power failure. If this happens, unplug the unit and wait approximately 10 seconds. Then, plug the unit in again.

TABLE OF CONTENTS

FOR THE USER	4	7. CONTROLS	11
1. USING THIS UNIT	4	7.1 Setting Extended Defrost	11
1.1 Your ventilation system	4	7.2 Electrical Connection to Optional Wall Control	12
1.2 Integrated Control	4	7.2.1 Altitude or Platinum	13
2. USER SERVICING INSTRUCTIONS	5	7.2.2 Deco-Touch	13
2.1 Quarterly Maintenance	5	7.2.3 Lite-Touch Constructo, Simple-Touch Constructo or Lite-Touch Bronze	13
2.2 Annual Maintenance	5	7.2.4 Constructo or Bronze	13
3. USER'S TROUBLESHOOTING	5	7.2.5 Optional Auxiliary Controls	13
4. WARRANTY	6	9. BALANCING THE UNIT	14
FOR THE INSTALLER	4	10. SERVICE PARTS	14
5. AIR DISTRIBUTION	7	11. WIRING DIAGRAM	16
6. INSTALLATION	7	12. TROUBLESHOOTING	17
6.1 Preparing the unit	7		
6.2 Locating the Unit	7		
6.3 Installing the Ductwork and the registers	8		
6.3.1 Fully Ducted System	8		
6.3.2 Exhaust Ducted System - Supply Side	8		
6.3.3 Exhaust Ducted System - Return Side	8		
6.3.4 Simplified Installation - Return/Supply	9		
6.3.5 Simplified Installation - Return/Return	9		
6.4 Installing the Exterior Hoods	9		
6.5 Connecting the ducts to the Unit	10		
6.6 Connecting the Drain	11		

PRODUCT REGISTRATION CARD - FICHE D'ENREGISTREMENT DU PRODUIT

IMPORTANT: Please complete and return this questionnaire within 10 days of your purchase to the address below. Note that only the questions on this side of the page are mandatory. Your answers will be used for market research studies and reports, and will help us to better serve you in the future. **IMPORTANT:** Veuillez remplir ce questionnaire et nous le retourner dans les 10 jours suivant votre achat à l'adresse inscrite en bas de la page. Veuillez noter que seules les questions de ce côté-ci de la page sont obligatoires. Vos réponses serviront à des études de marché et nous aideront à mieux vous servir dans l'avenir.

First name - Prénom		Last name - Nom de famille		
<input type="text"/>		<input type="text"/>		
Address - Adresse	Apt. no. - App.	City - Ville	Province	Postal code - Code postal
<input type="text"/>	<input type="text"/>	<input type="text"/>	<input type="text"/>	<input type="text"/>
Country - Pays	E-mail address - Courriel		Language preferred - Langue de correspondance	
<input type="text"/>	<input type="text"/>		<input type="text"/>	
Telephone no. (day) - N° de téléphone (jour)	Telephone no. (evening) - N° de téléphone (soir)		Date of purchase - Date d'achat	
<input type="text"/>	<input type="text"/>		<input type="text"/>	
Model no. - N° de modèle	Serial no. - N° de série			
<input type="text"/>	<input type="text"/>			

1. USING THIS UNIT

CAUTION

Before using this unit for the first time, please take the time to carefully read page 2 of this guide to ensure it is used safely and properly.

1.1 YOUR VENTILATION SYSTEM

This unit is designed to provide fresh air to your home while exhausting stale, humid air. By eliminating accumulated pollutants and humidity, it maintains an optimum air quality and an ideal relative humidity. It is equipped with a recovery core that is designed specifically to control excess humidity and reduce ventilation costs by recovering the heat or energy from the exhausted air, and using that same heat or energy to warm the fresh air being supplied. This recovery process is accomplished in such a way that the stale air is never mixed with the fresh air.

When the outdoor temperature is below -5°C (23°F), recovery creates frost in the module. To maintain proper operation, the unit is programmed to defrost the recovery module. The defrost duration and frequency vary according to the outdoor temperature. After defrosting, the unit returns to the operating mode selected by the user.

1.2 INTEGRATED CONTROL

Unit Booting Sequence

The unit's booting sequence is similar to a personal computer's booting sequence. Each time the unit is plugged in after being unplugged, or after a power failure, it will perform a 30-second booting sequence before starting to operate. **No command will be taken until the unit is fully booted.**

This unit is equipped with an **integrated control**, located on its electrical compartment.

- Use the integrated push-button to go from OFF to Low Speed, to High Speed, and back to OFF.
- The color of the LED indicator shows what speed the unit is running in:

LED COLOR	RESULTS
AMBER	Unit is in Low speed
GREEN	Unit is in High speed
NO LIGHT	Unit is OFF or controlled by a main control

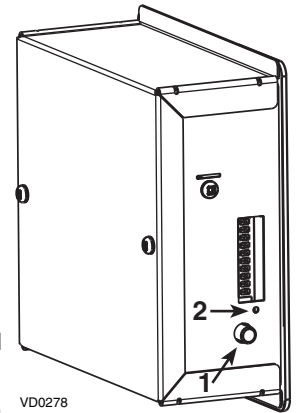

For more convenience, this unit can also be controlled using an optional wall control. **When using an optional main control, unit must be set to OFF using the integrated control.**

For more information about their operation modes refer to the *Main and auxiliary wall control User Guide*, included with the ventilation unit and also available at www.vanee.ca or www.venmar.ca.

VD0278

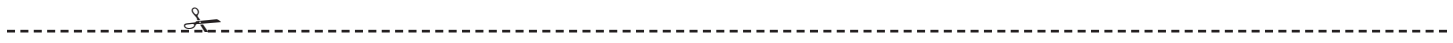

Would you like to receive occasional informational e-mail offers including product updates and special promotions from us? **Yes/No**

What problem were you trying to solve with your purchase? (Check each one that applies to you.)

- Bad odors
- Respiratory problems
- Excess of humidity
- Temperature standardization
- Lack of fresh air
- Dust
- Mildew
- Allergies
- No specific problems
- Others

Who installed your unit?

- Home builder
- Recommended installer
- Friend / family
- Contractor
- Yourself

Please read the following list of criteria carefully. Indicate the importance of your purchase decision on a scale of 1 (less important) to 5 (most important).

- ___ Price
- ___ Warranty
- ___ Product design
- ___ Ventilation capacity
- ___ Filter maintenance indicator
- ___ Filtration quality
- ___ Recirculation
- ___ Heat recovery
- ___ Controls
- ___ Ease of cleaning
- ___ Manufacturer's reputation
- ___ Ease of use
- ___ Noise level
- ___ Other

Aimeriez-vous recevoir plus de détails sur nos promotions, offres de rabais et mises à jour de nos produits? **Oui/Non**

Quels problèmes essayez-vous de résoudre par cet achat? (Cochez toutes les cases pertinentes)

- Mauvaises odeurs
- Problèmes respiratoires
- Excès d'humidité
- Uniformisation de la température
- Manque d'air frais
- Poussières
- Moisissures
- Allergies
- Pas de problèmes spécifiques
- Autres (Précisez SVP)

Qui a installé l'appareil?

- Constructeur de la maison
- Installateur recommandé
- Ami/membre de la famille
- Entrepreneur
- Vous-même

Veillez lire la liste des critères de sélection ci-dessous. Sur une échelle de 1 (étant le moins important) à 5 (étant le plus important), veuillez indiquer l'importance de chacun d'entre eux dans votre décision d'achat.

- ___ Prix
- ___ Garantie
- ___ Design du produit
- ___ Débit de ventilation
- ___ Indicateur d'entretien du filtre
- ___ Qualité de filtration
- ___ Recirculation
- ___ Récupération de chaleur
- ___ Récupération d'énergie
- ___ Fonctions
- ___ Facilité de nettoyage
- ___ Réputation du fabricant
- ___ Simplicité d'utilisation
- ___ Niveau de bruit
- ___ Autres (Précisez SVP)

Are you connected? Please do not hesitate to complete the product registration card via our Web site at www.bnv.ca

Enregistrez-vous en ligne! N'hésitez pas à remplir la fiche d'enregistrement du produit sur notre site Internet au www.bnv.ca

2. USER SERVICING INSTRUCTIONS

2.1 QUARTERLY MAINTENANCE

⚠ WARNING

- **Risk of electric shock. Before performing any maintenance or servicing, always disconnect the unit from its power source.**
- **When cleaning the unit, it is recommended to wear safety glasses and gloves.**

1. Unplug unit.
2. Unlatch the door. Lift the panel towards you. Hold it firmly and hit on the right side of the panel. The door will slide to the left.
3. Clean the inside of the door with a damp cloth.
4. Clean filters:
 - Remove filters.
 - Vacuum to remove most of the dust.
 - Wash with a mixture of warm water and mild soap. You may add bleach if you wish to disinfect (one tablespoon per gallon). Rinse thoroughly. Shake filters to remove excess water and let dry.
5. Clean the condensation tray with a damp cloth.
6. Check the exterior air intake hood:
 - Make sure there are no leaves, twigs, ice or snow that could be drawn into the vent.
 - Clean if necessary.

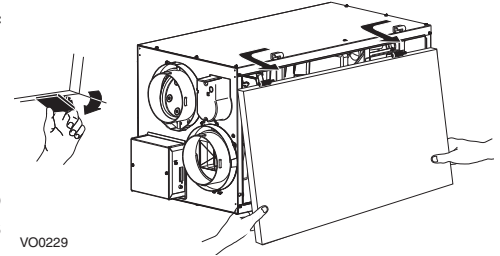

CAUTION

Even a partial blocking of this air vent could cause the unit to malfunction.

7. Reassemble the components.
8. Reconnect power supply.

2.2 ANNUAL MAINTENANCE

1. Perform Quarterly Maintenance up to step 6.
2. Clean the core as follows:
 - Remove the core.
 - Let it soak in a mixture of cold or lukewarm water and mild soap (dishwashing liquid).
 - Rinse thoroughly.
 - Shake the core to remove excess water and let it dry.
3. Clean blower assembly using a vacuum cleaner with a soft brush attachment to remove the dust.
4. Reassemble the components.
5. Reconnect power supply.

3. USER'S TROUBLESHOOTING

PROBLEM	YOU SHOULD TRY THIS	
Nothing works.	• See if the unit is plugged in and receiving power from the house circuit breaker or fuse.	
Noisy unit.	• Clean the unit (see Section 2). If the problem is not solved, contact your installer.	
Condensation on windows (air too humid).	<ul style="list-style-type: none"> • Operate the unit at maximum speed (MAX.) during activities generating excess humidity (family gatherings, extra cooking, etc.). • Leave curtains half-open to allow air circulation. • Store all firewood in a closed room with a dehumidifier or in a well ventilated room, or store the wood outdoors. • Keep the temperature in your house above 18°C (64°F). 	
Air too dry.	<ul style="list-style-type: none"> • Operate the unit at low speed (MIN.). • Temporarily switch to the intermittent mode (if available). 	• Temporarily use a humidifier.
Air too cold at the air supply grille.	<ul style="list-style-type: none"> • Make sure the outdoor hoods are not blocked. • Operate the unit at low speed (MIN.). • Have the system's balancing checked. 	<ul style="list-style-type: none"> • Have the unit's defrost system checked. • Install a duct heater.

Contact customer service at 1-800-567-3855 for any unresolved issue.

4. WARRANTY

This ventilation unit is a high-quality product, built and packaged with care. The manufacturer warrants to the original purchaser of its product, that such products will be free from defects for the period stated below, from the date of original purchase. For all units, the warranty covers parts only against any operational defect. This 5-year warranty is subject to performance of the core maintenance according to the recommendations in this manual. The heat recovery core (HRV) has a limited lifetime warranty. If any defect should occur, we urge you to read the user guide carefully. If the problem persists, observe the following rules:

RULES TO FOLLOW

If the unit is defective, contact your ventilation contractor (see address on your manual's cover page). The contractor will determine with you the reason for the defect, and if needed, do the replacement or repair. If ever it is impossible to reach your ventilation contractor, call 1-800-567-3855 (North America); the personnel will be pleased to give you the phone number of a distributor or service center near you.

REPLACEMENT PARTS AND REPAIR

In order to ensure your ventilation unit remains in good working condition, you must use the manufacturer's genuine replacement parts only. The manufacturer's genuine replacement parts are specially designed for each unit and are manufactured to comply with all the applicable certification standards and maintain a high standard of safety. Any third party replacement part used may cause serious damage and drastically reduce the performance level of your unit, which will result in premature failing. The manufacturer also recommends that you contact a service depot certified by the manufacturer for all replacement parts and repair.

BILL OF PURCHASE

No replacement or repair covered by the warranty will be carried out unless the unit is accompanied by a copy of the original bill of purchase. Please retain your original.

MISCELLANEOUS COSTS

In each case, the labor costs for the removal of a defective part and/or installation of a compliant part will not be covered by the manufacturer.

CONDITIONS AND LIMITATIONS

These units are created for **residential use only** and must be used in a building as defined below:

- Building:** All structures zoned and/or erected for the act, process or art of human or animal habitation and/or the storage or warehousing of goods.
- Residential use:** Dwelling, lodging, suite: Building, or part of a building, intended to act as either the domicile to one or several people which can include general sanitary, food consumption and rest facilities. Buildings of only one room or a group of rooms including those occupied by a tenant or owner; comprise the lodgings, the individual rooms of the motels, hotels, rooming/lodging houses, boarding/half-way/foster homes, dormitories, and suites, as well as the stores and the business establishments constituted by only one room in a dwelling.
- Commercial use:** Agricultural establishment, commercial establishment for assembly, care, or detention: Building or part of a building that does not contain a dwelling, situated on land dedicated to agriculture or farming and used primarily to shelter animals, or for the production, the storage or the treatment of agricultural or horticultural products or animal food. Building or part of a building, used for the display or retail of goods, professional or personal services, or commodities. Building, or part of a building used by persons gathering for civic activities, religious or political assembly, tourism, educational/vocational training, recreation or the consumption of food or drink. Building, or part of a building used to shelter persons of impaired physical or psychological states, persons requiring palliative care or medical treatments, or persons for reasons out of their control, cannot escape harm or threat of danger autonomously.
- Industrial use:** Building, or part of a building, used for the assembly, the manufacture, the creation, the treatment, the repair or the storage of products and combustible materials and that contain fuels that when ignited or exploded in sufficient quantity may constitute a risk of fire.

The above warranty applies to all cases where the damage is not a result of poor installation, improper use, mistreatment or negligence, acts of God, or any other circumstances beyond the control of the manufacturer. Furthermore, the manufacturer will not be held responsible for any bodily injury or damage to personal property or real estate, whether caused directly or indirectly by the unit. This warranty supersedes all prior warranties.

CAUTION

- Before installing this unit, please take the time to carefully read page 2 of this guide to ensure it is installed safely and properly.
- For Novoclimat compliant installation requirements, please refer to the current Novoclimat Program criterias.

5. AIR DISTRIBUTION

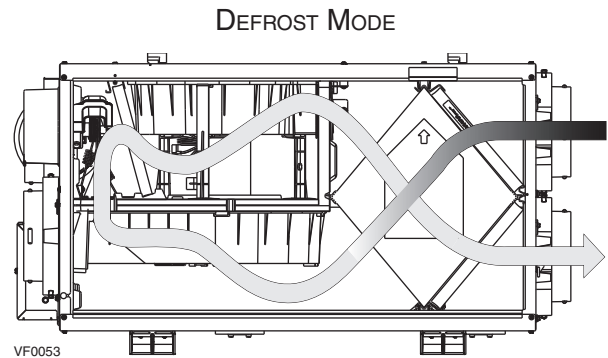
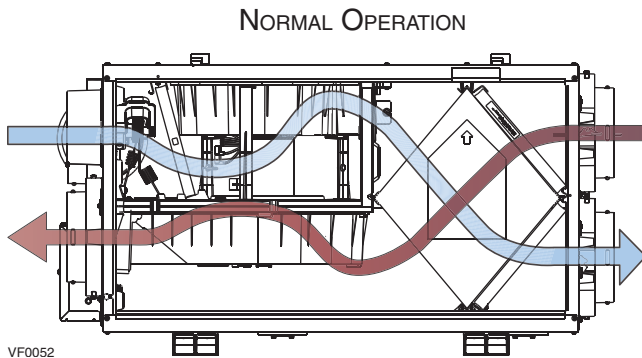

6. INSTALLATION

6.1 PREPARING THE UNIT

⚠ WARNING

When performing installation, servicing or cleaning the unit, it is recommended to wear safety glasses and gloves.

Inspect the exterior of the unit for shipping damage. Make sure that there is no damage to the door, ports, power cord, etc.

Before installing the unit, remove the shipping bracket by unscrewing its wing nut and loosening both retaining screws.

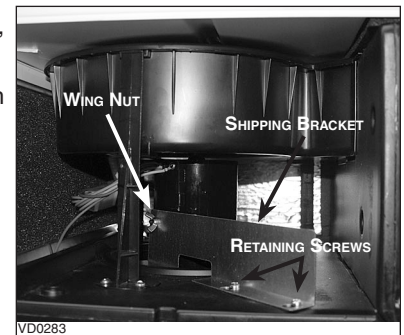

6.2 LOCATING THE UNIT

CAUTION

HRV Solo 1.5ES and HRV Solo 2.0ES units can be installed in normal or reverse position (upside down). When installed in reverse position in a cold region where outdoor temperature could drop below -20°C (-4°F) for more than 5 days in a row, these units must always be set in extended defrost. See Section 7.1 Setting Extended Defrost.

Choose an **appropriate location** for the unit:

- Within an area of the house where the **ambient temperature is kept between 10°C (50°F) and 40°C (104°F)**
- Away from living areas (dining room, living room, bedroom), if possible
- So as to provide easy access to the interior cabinet for quarterly and annual maintenance, and to the control panel on the side of the unit
- Close to an exterior wall, so as to limit the length of the insulated flexible duct to and from the unit
- Close to a drain. If no drain is close by, use a pail to collect run-off
- Away from hot chimneys, electrical panel and other fire hazards
- Allow for a power source (standard outlet)

Hang the unit with the 4 chains and springs provided (see illustrations at right).

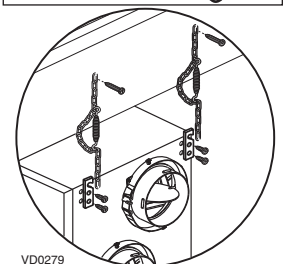
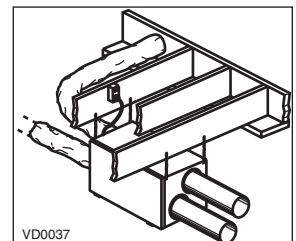

6.3 INSTALLING THE DUCTWORK AND THE REGISTERS

⚠ WARNING

- **Never install a stale air exhaust register in a closed room where a combustion device operates, such as a gas furnace, a gas water heater or a fireplace.**
- **When performing duct connections, always use approved tools and materials. Respect all corresponding laws and safety regulations. Please refer to your local building code.**

6.3.1 FULLY DUCTED SYSTEM

Stale air exhaust ductwork:

- Install registers in areas where contaminants are produced: Kitchen, bathrooms, laundry room, etc.
- Install registers on an interior wall, 6 to 12 inches (152 to 305 mm) away from the ceiling OR install them in the ceiling.
- Install the kitchen register at least 4 feet (1.2 m) away from the range.

Fresh air distribution ductwork:

- Install registers in bedrooms, dining room, living room and basement.
- Install registers either in the ceiling or high on the walls with the airflow directed towards the ceiling.
- If a register must be installed in the floor, direct the air flow up the wall.

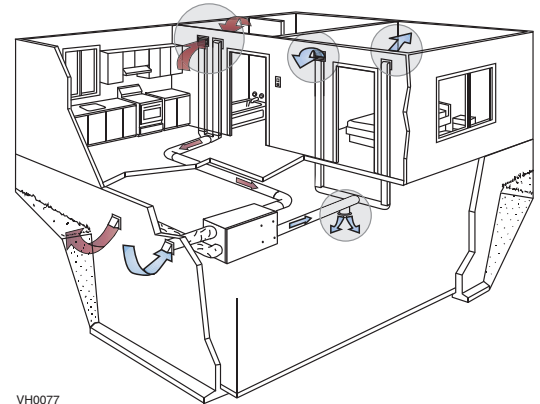

6.3.2 EXHAUST DUCTED SYSTEM - SUPPLY SIDE

CAUTION

When performing duct connections to the furnace supply duct, use metal ducts appropriately sized to support the additional airflow produced by the unit.

Stale air exhaust ductwork:

- Install registers in areas where contaminants are produced: Kitchen, bathrooms, laundry room, etc.
- Install registers on an interior wall, 6 to 12 inches (152 to 305 mm) away from the ceiling OR install them in the ceiling.
- Install the kitchen register at least 4 feet (1.2 m) away from the range.

Fresh air distribution ductwork:

- Cut an opening into the furnace supply duct at least 18 inches (0.5 m) away from the furnace.
- Connect this opening to the fresh air distribution port of the unit (use metal ducts, see illustration at right).
- Make sure that the duct forms an elbow inside the furnace ductwork.

NOTE: For this type of installation, it is recommended, however, not essential, that the furnace blower be synchronized with the unit.

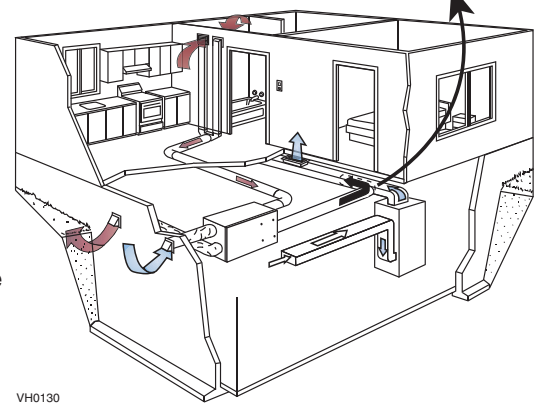
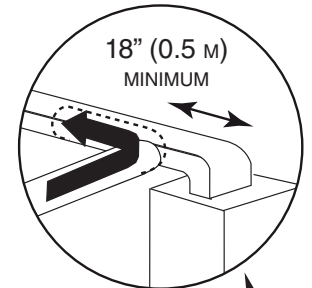

6.3.3 EXHAUST DUCTED SYSTEM - RETURN SIDE

Stale air exhaust ductwork:

- Install registers in areas where contaminants are produced: Kitchen, bathrooms, laundry room, etc.
- Install registers on an interior wall, 6 to 12 inches (152 to 305 mm) away from the ceiling OR install them in the ceiling.
- Install the kitchen register at least 4 feet (1.2 m) away from the range.

Fresh air distribution ductwork:

- Cut an opening into the furnace return duct not less than 10 feet (3.1 m) away from the furnace (A+B).
- Connect this opening to the fresh air distribution port of the unit (see illustration at right).

NOTE: For this type of installation, it is recommended, however, not essential, that the furnace blower be synchronized with the unit.

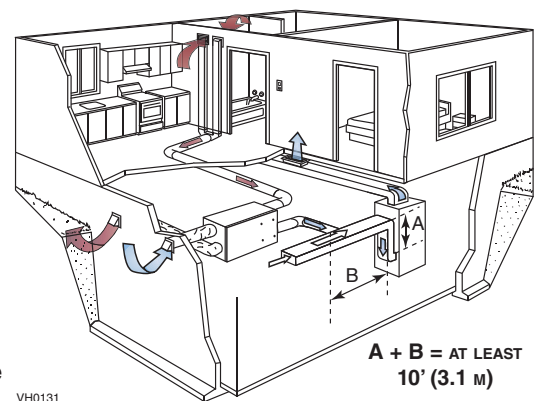

**A + B = AT LEAST
10' (3.1 m)**

For the Installer

6.3.4 SIMPLIFIED INSTALLATION - RETURN/SUPPLY

CAUTION

When performing duct connections to the furnace supply duct, use metal ducts appropriately sized to support the additional airflow produced by the unit.

Stale air exhaust ductwork:

- Cut an opening into the furnace return duct not less than 10 feet (3.1 m) (A + B) away from the furnace.
- Connect this opening to the stale air intake port of the unit (as shown above).

Fresh air distribution ductwork:

- Cut an opening into the furnace supply duct at least 18 inches (0.5 m) away from the furnace.
- Connect this opening to the fresh air distribution port of the unit (use metal ducts, see illustration at right).
- Make sure that the duct forms an elbow inside the furnace ductwork.

NOTE : For this type of installation, it is recommended, however, not essential, that the furnace blower be synchronized with the unit.

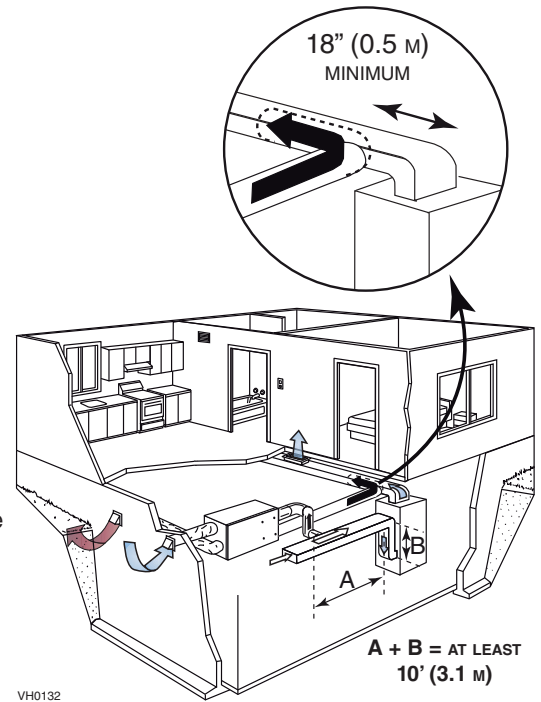

6.3.5 SIMPLIFIED INSTALLATION - RETURN/RETURN

Stale air exhaust ductwork:

CAUTION

For this type of installation, the furnace must always be synchronized with the unit. See section 8.

- Cut an opening into the furnace return duct not less than 10 feet (3.1 m) (A + B) away from the furnace.
- Connect this opening to the stale air intake port of the unit.

Fresh air distribution ductwork:

- Cut an opening into the furnace supply duct at least 18 inches (0.5 m) away from the furnace.
- Connect this opening to the fresh air distribution port of the unit (use metal ducts, see illustration at right).
- Make sure that the duct forms an elbow inside the furnace ductwork.
- Make sure that both connections to the furnace return duct are at least 3 feet (1 m) apart (C).

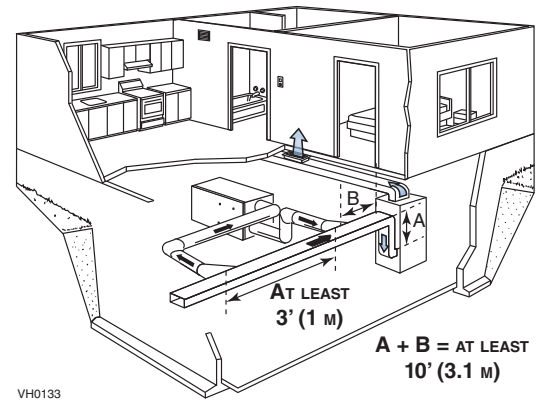

6.4 INSTALLING THE EXTERIOR HOODS

Refer to illustration at right to connect the insulated duct to the hoods. An "Anti-Gust Intake Hood" should be installed in regions where a lot of snow is expected to fall.

⚠ WARNING

Make sure that both hoods are at least 18 inches above the ground and that the intake hood is at least 6 feet (1.8 m) away from any of the following:

- Exhaust hood
- Dryer exhaust, high efficiency furnace vent, central vacuum vent
- Gas meter exhaust, gas barbecue-grill
- Any exhaust from a combustion source
- Garbage bin and any other source of contamination

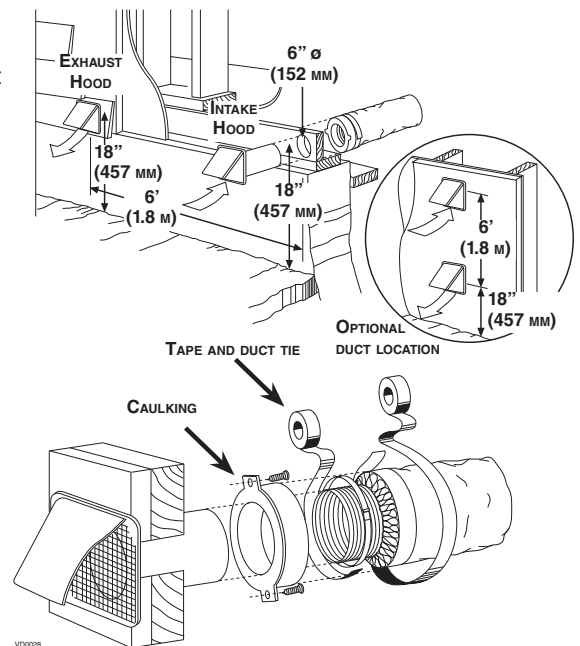

6.5 CONNECTING THE DUCTS TO THE UNIT

CAUTION

- If ducts have to go through an unconditioned space (e.g.: attic), always use insulated ducts.
- Make sure the vapor barrier on the insulated ducts does not tear during installation to avoid condensation within the ducts.
- Do not use screws to connect rigid ducts to the ports.

Insulated flexible ducts

Use the following procedure to connect the insulated flexible ducts to the cold side ports (stale air to outdoors and fresh air from outdoors).

1. Pull back the insulation to expose the flexible duct and place the flexible duct **over inner port ring**.
2. Install good quality **aluminum duct tape** on the flexible duct to prevent water leakage.
3. Attach the flexible duct to the port using a tie wrap.
4. Pull the insulation over the joint and tuck it **between the inner and outer rings** of the double collar.
5. Pull down the vapor barrier (shaded part in illustrations below) **over the outer ring** to cover it completely. Fasten the vapor barrier in place using the port strap (included in parts bag). To do so, insert one collar pin through the vapor barrier and first strap hole, then insert the other collar pin through the vapor barrier and center strap hole and close the loop by inserting the first collar pin in the last strap hole.

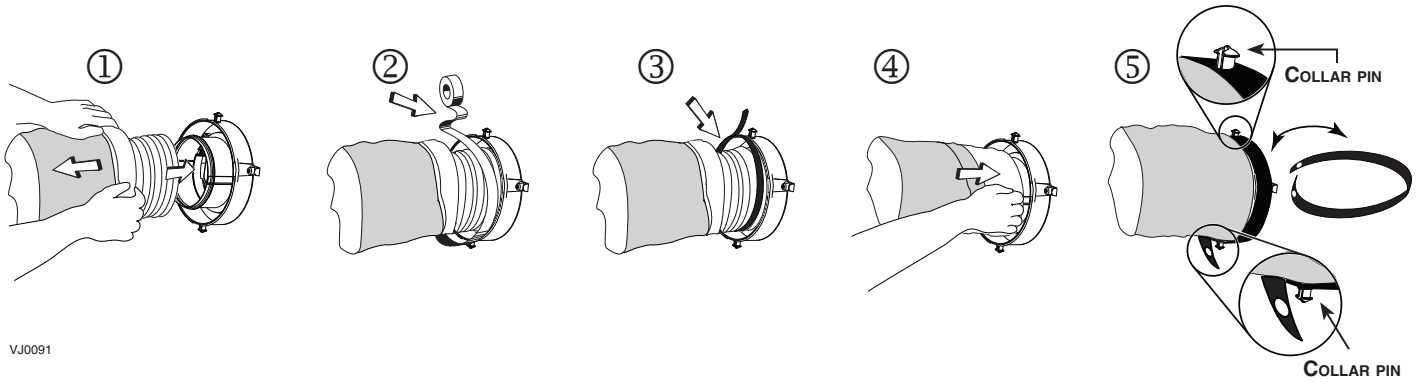

VJ0091

Rigid ducts

To prevent water leakage from ducts, use good quality aluminum duct tape to connect the rigid ducts to the ports. Do not use screws.

Make sure that both balancing dampers are left in a fully open position before connecting the **Fresh air to building port** and **Stale air from building port** (as shown in illustration at right).

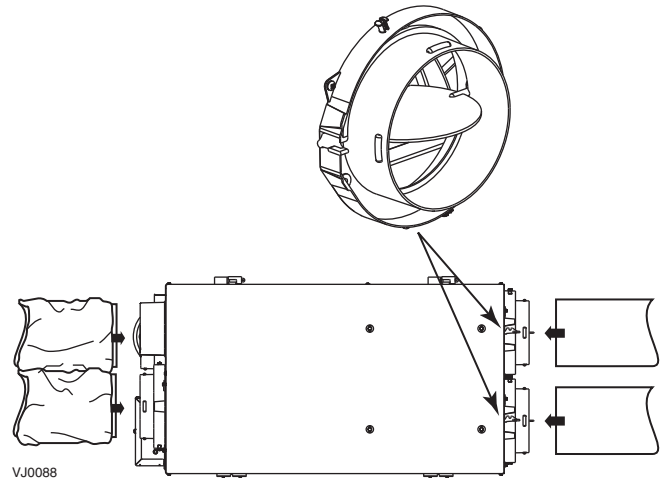

VJ0088

For the Installer

6.6 CONNECTING THE DRAIN

1. Cut 2 sections of plastic tubing of at least 12" each.
2. Connect each one of them to the inner drain fittings located under the unit.
3. Join their other ends to the "T" junction and remaining tubing as illustrated. This will prevent the unit from drawing unpleasant odors from the drain source.

FOR HRV SOLO 1.5ES AND HRV SOLO 2.0ES UNITS ONLY:

4. Insert both drain plugs (included in parts bag) in the alternate drain fittings located on top of the unit.

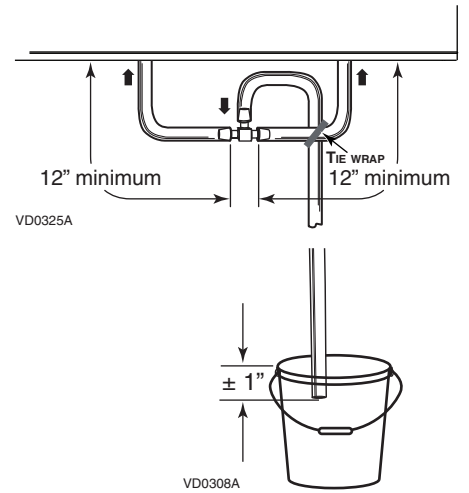
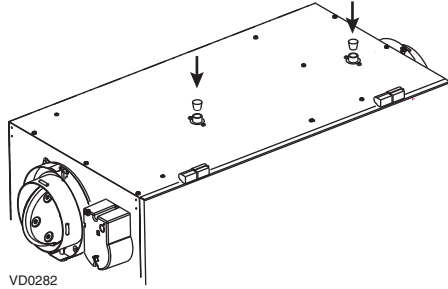

7. CONTROLS

7.1 SETTING EXTENDED DEFROST

CAUTION

For HRV Solo 1.5ES and HRV SOLO2.0ES units only: when installed in reverse position (upside down) in a cold area where outside temperature could drop below -20°C (-4°F) for more than 5 days in a row, the unit must always be set in extended defrost.

These units are factory set to normal defrost. In cold areas, it may be necessary to setup extended defrost. To do so, during the first 5 seconds of the booting sequence, while the integrated control LED is GREEN, press on the integrated push button (about 3 seconds) until the LED turns AMBER.

⚠ WARNING

Always disconnect the unit before making any connections. Failure in disconnecting power could result in electrical shock or damage of the wall control or electronic module inside the unit.

CAUTION

Never install more than one optional main wall control per unit. Make sure that the wires do not short-circuit between themselves or by touching any other components on the wall control. Avoid poor wiring connections. To reduce electrical interference (noise) potential, do not run wall control wiring next to control contactors or near light dimming circuits, electrical motors, dwelling/building power or lighting wiring, or power distribution panel.

- Use the terminal connector included in the installation kit to perform the electrical connection for main and optional wall controls.
- Make sure all wires are correctly inserted in their corresponding holes in the terminal block. A wire is correctly inserted when its orange receptacle is lower than another one without wire. On picture below, wire **A** is correctly inserted, but wire **B** is not.
- Once the wall control(s) connections have been made, insert the terminal connector in the electrical compartment.
- If an optional main control is being installed, make sure that the unit is set to OFF using the integrated push-button.

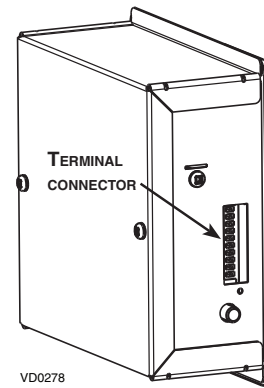
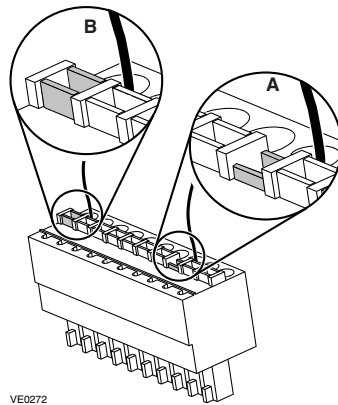

Use the chart below to verify compatibility with the optional controls before making any connection.

	Main Controls	Auxiliary Controls
HRV CONSTRUCTO 1.5ES HRV CONSTRUCTO 2.0ES	<ul style="list-style-type: none"> • Deco-Touch • Lite-Touch Constructo • Constructo 	<ul style="list-style-type: none"> • Dehumidistat • 20-minute lighted push button • 60-minute crank timer
HRV SOLO 1.5ES HRV SOLO 2.0ES	<ul style="list-style-type: none"> • Altitude • Deco-Touch • Lite-Touch Constructo • Simple Touch Constructo • Constructo 	<ul style="list-style-type: none"> • Dehumidistat • 20/40/60-minute push-button timer • 60-minute crank timer
HRV NOVOFIT 1.5ES HRV NOVOFIT 2.0ES	<ul style="list-style-type: none"> • Altitude • Deco-Touch 	<ul style="list-style-type: none"> • 20/40/60-minute push-button timer • 60-minute crank timer
100H 200H	<ul style="list-style-type: none"> • Deco-Touch • Lite-Touch Bronze • Bronze 	<ul style="list-style-type: none"> • Dehumidistat • 20-minute lighted push button • 60-minute crank timer
NOVO+ 100H NOVO+ 200H	<ul style="list-style-type: none"> • Platinum • Deco-Touch 	<ul style="list-style-type: none"> • 20/40/60-minute push-button timer • 60-minute crank timer

For the Installer

7.2.1 ALTITUDE OR PLATINUM

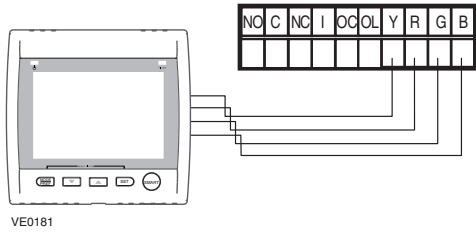

7.2.2 DECO-TOUCH

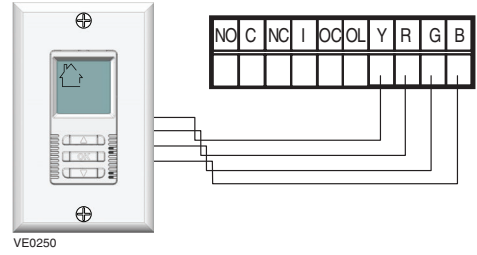

7.2.3 LITE-TOUCH CONSTRUCTO, SIMPLE-TOUCH CONSTRUCTO OR LITE-TOUCH BRONZE

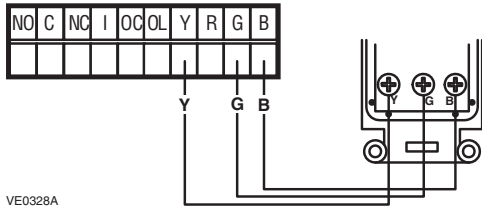

7.2.4 CONSTRUCTO OR BRONZE

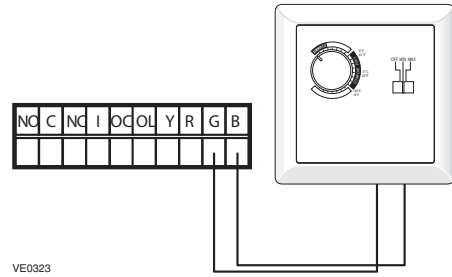

7.2.5 OPTIONAL AUXILIARY CONTROLS

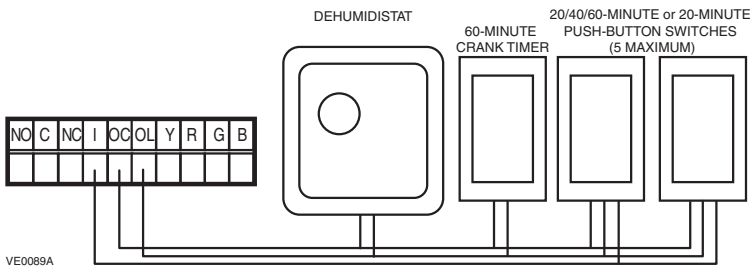

8. CONNECTION TO THE FURNACE

⚠ WARNING

Never connect a 120-volt AC circuit to the terminals of the furnace interlock (standard wiring). Only use the low voltage class 2 circuit of the furnace blower control.

FOR A FURNACE CONNECTED TO A COOLING SYSTEM:

On some older thermostats, energizing the “R” and “G” terminals at the furnace has the effect of energizing “Y” at the thermostat and thereby turning on the cooling system. If you identify this type of thermostat, you must use the ALTERNATE FURNACE INTERLOCK WIRING.

STANDARD FURNACE INTERLOCK WIRING

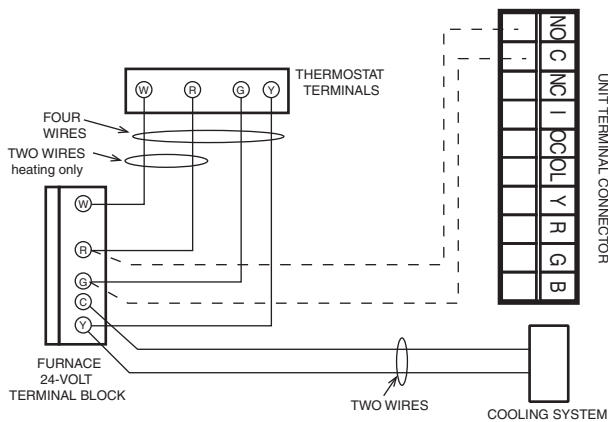

ALTERNATE FURNACE INTERLOCK WIRING

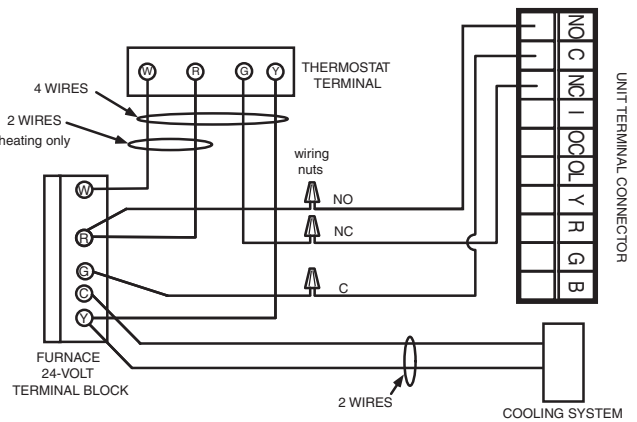

VE0108A

9. BALANCING THE UNIT

PREPARATION

Follow these steps to ensure accurate measurements:

- Seal all the ductwork with tape. Close all windows and doors.
- Turn off all exhaust devices such as range hood, dryer and bathroom fans.
- Make sure the balancing dampers are fully open.
- If the installation is in any way connected to the ductwork of the cold air return of a furnace/air handler, make sure that the furnace/air handler blower is ON. If not, leave furnace/air handler blower OFF.
- If the outside temperature is below 0°C/32°F, make sure the unit is not running in defrost while balancing by waiting 10 minutes after plugging the unit in.
- Set the unit to high speed.

BALANCING PROCEDURE

1. Place the magnehelic gauge on a level surface and adjust it to zero.
2. Connect tubing from gauge to EXHAUST airflow pressure taps (see diagram on unit door).
3. Be sure to connect the tubes to their appropriate high/low fittings. If the gauge drops below zero, reverse the tubing connections.
4. Note the CFM value from balancing chart on the unit.
5. Repeat steps 3 and 4, but to FRESH airflow pressure taps.
6. Using the appropriate adjustable balancing damper, lower the highest value so it matches the lowest value. A difference up to ± 10 cfm is acceptable.
7. Secure both dampers in place with a fastening screw (included in the hardware kit).
8. Write the required airflow information on a label and stick it near the unit for future reference (date, maximum speed air flows, your name, phone number and business address).

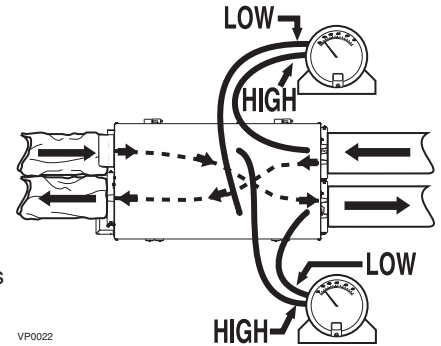

10. SERVICE PARTS

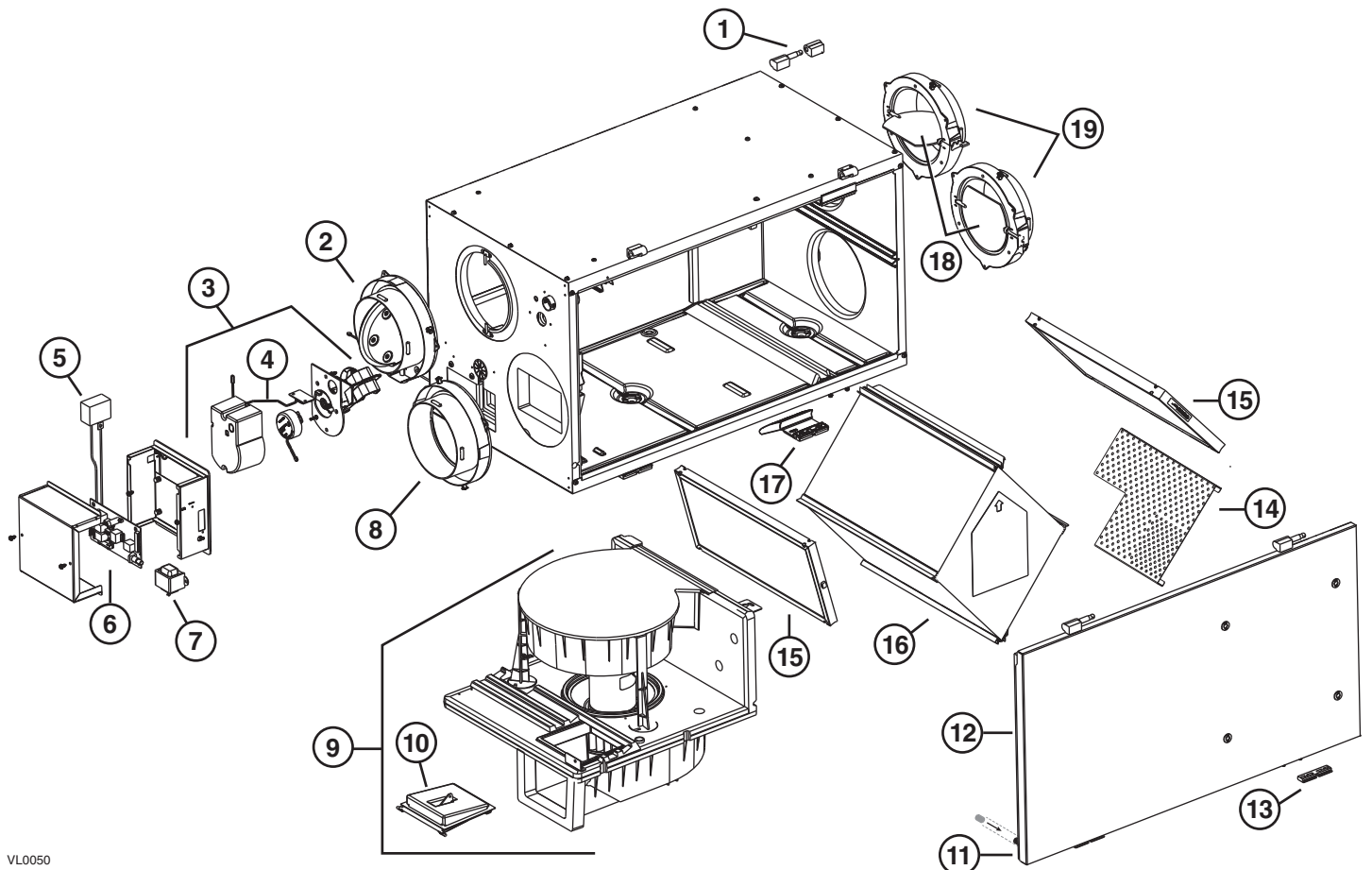

Item	Description	Part no.	HRV Constructo 1.5ES 46110	HRV Constructo 2.0ES 47110	HRV Solo 1.5ES 46720	HRV Solo 2.0ES 47720	HRV Novofit 1.5ES 46121	HRV Novofit 2.0ES 47121	100H 1601706	200H 1601708	NOVO+ 100H 1601717	NOVO+ 200H 1601719
1	Hinge assembly kit	13036	1	1	1	1	1	1	1	1	1	1
2	Damper supply port assembly	17245	1	1	1	1	1	1	1	1	1	1
3	Damper system actuator (incl. no. 4)	17235	1	1	1	1	1	1	1	1	1	1
4	Thermistor kit	17242	1	1	1	1	1	1	1	1	1	1
5	Capacitor 7.5 µF	17240	1	1	1	1	1	1	1	1	1	1
6	Electronic board	60809	1	1	1				1	1		
		60810			1	1	1	1			1	1
7	Transformer	17244	1	1	1	1	1	1	1	1	1	1
8	Double collar port	60818	1	1	1	1	1	1	1	1	1	1
9	Blower assembly (incl. no. 10)	60804	1		1		1		1		1	
		60805		1		1		1		1		1
10	Square damper kit	17243	1	1	1	1	1	1	1	1	1	1
11	Magnet switch	19060	1	1	1	1	1	1	1	1	1	1
12	Door assembly (incl. hinges and latches)	60797	1	1	1	1	1	1				
		60815							1	1	1	1
13	Door latches (keeper) (2) and screws (4)	00887	1	1	1	1	1	1	1	1	1	1
		00601	1	1	1	1	1	1	1	1	1	1
14	Diffuser	60822	1	1	1	1	1	1	1	1	1	1
15	Filter kit	60800	1	1	1	1	1	1	1	1	1	1
16	Core	60802	1		1		1		1	1		
		60803		1		1		1			1	1
17	Door latches (2) and screws (4)	05960	1	1	1	1	1	1	1	1	1	1
		00601	1	1	1	1	1	1	1	1	1	1
18	Balancing damper	02253	1	1	1	1	1	1	1	1	1	1
19	Balancing double collar port	02256	1	1	1	1	1	1	1	1	1	1
*	Terminal connector	16416	1	1	1	1	1	1	1	1	1	1
*	Hardware kit	20510	1	1			1	1	1	1	1	1
		20606			1	1						

* Not shown.

Replacement parts and repairs

In order to ensure your ventilation unit remains in good working condition, you must use the manufacturer's genuine replacement parts only. The manufacturer's genuine replacement parts are specially designed for each unit and are manufactured to comply with all the applicable certification standards and maintain a high standard of safety. Any third party replacement part used may cause serious damage and drastically reduce the performance level of your unit, which will result in premature failing. The manufacturer also recommends contacting a certified service depot for all replacement parts and repairs.

11. WIRING DIAGRAM

⚠ WARNING

- Risk of electric shocks. Before performing any maintenance or servicing, always disconnect the unit from its power source.
- This product is equipped with an overload protection (fuse). A blown fuse indicates an overload or a short-circuit situation. If the fuse blows, unplug the product from the outlet. Discontinue using the unit and contact technical support.

LOGIC DIAGRAM

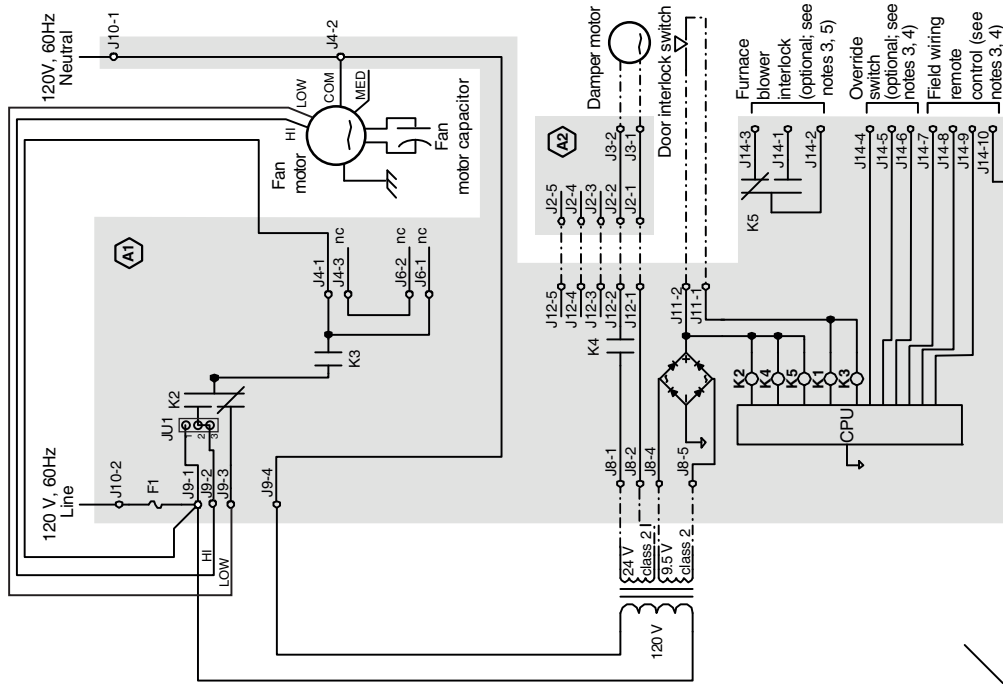

WIRING DIAGRAM

- NOTES**
1. Protected against fire with UL listed/CSA Certified line fuse (3A, 3AG Type).
 2. If any of the original wire, as supplied, must be replaced, use the same equivalent wire.
 3. Field wiring must comply with applicable codes, ordinances and regulations.
 4. Remote controls (Class 2 circuit) available, see instruction manual.
 5. Furnace fan circuit must be class 2 circuit only.

⚠ Critical characteristic.

ref: 24596_REV-A

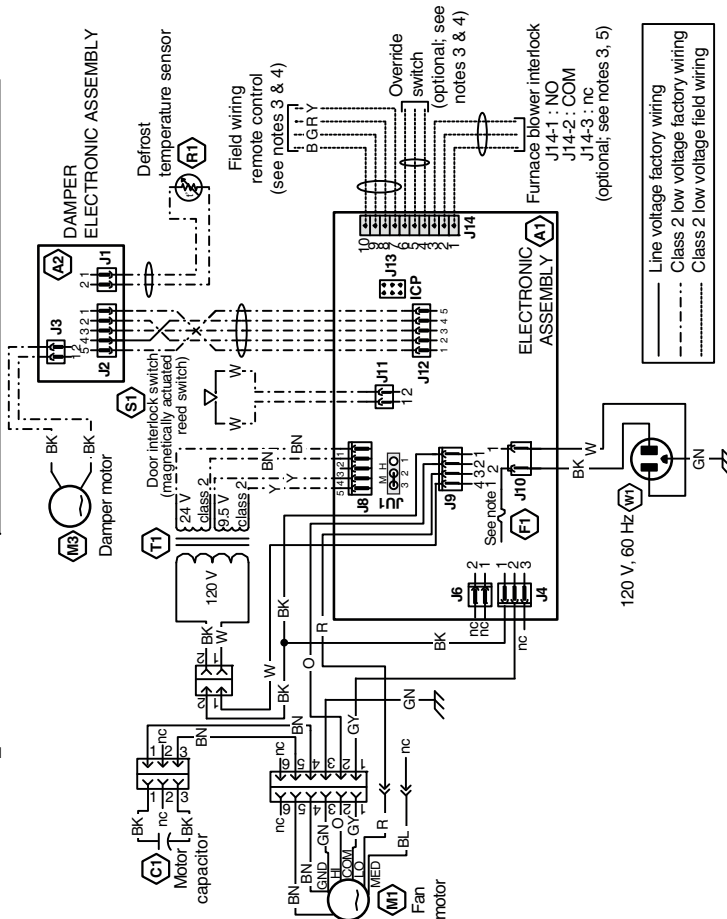

Line voltage factory wiring
 Class 2 low voltage factory wiring
 Class 2 low voltage field wiring

COLOR CODE

BK	BLACK	O	ORANGE
BL	BLUE	R	RED
BN	BROWN	W	WHITE
GY	GRAY	Y	YELLOW
GN	GREEN	nc	no connection

12. TROUBLESHOOTING

⚠ WARNING

Risk of electric shocks. Electronic board connections must be checked by qualified personnel only.

If the integrated LED of the unit is flashing, the unit sensors detected a problem. See the table below to know more about the nature of the problem.

LED Signal	Error Type	Action
LED flashes GREEN (double blink)	Thermistor error	Replace the thermistor kit.
LED flashes AMBER	Damper error	Go to page 18 "Unit does not work".

⚠ WARNING

A few diagnosis procedures may require the unit to be in operation while proceeding. Open the unit door and bypass its magnetic switch by putting the door white magnet on it. Be careful with moving and/or live parts.

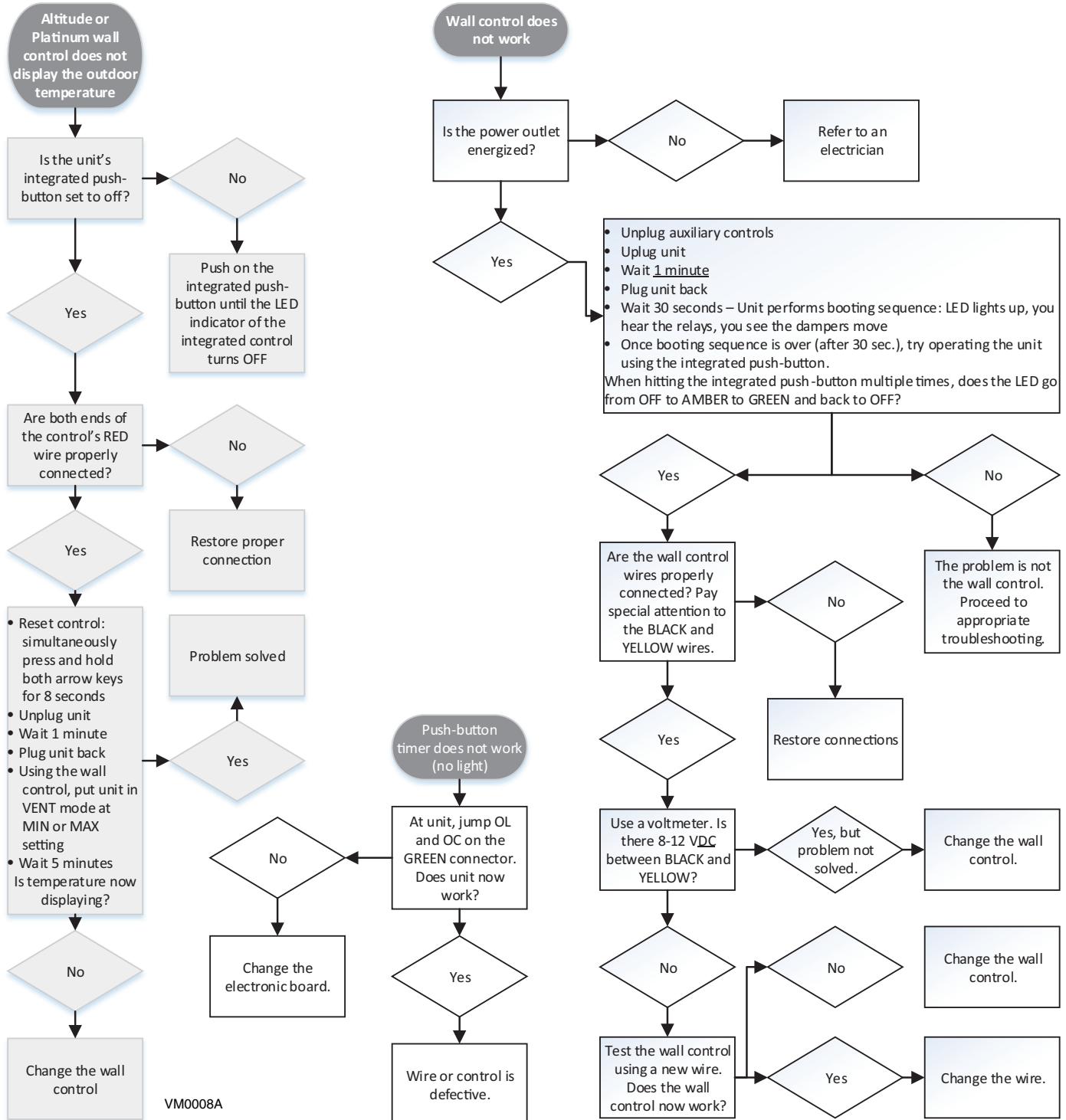

VM0008A

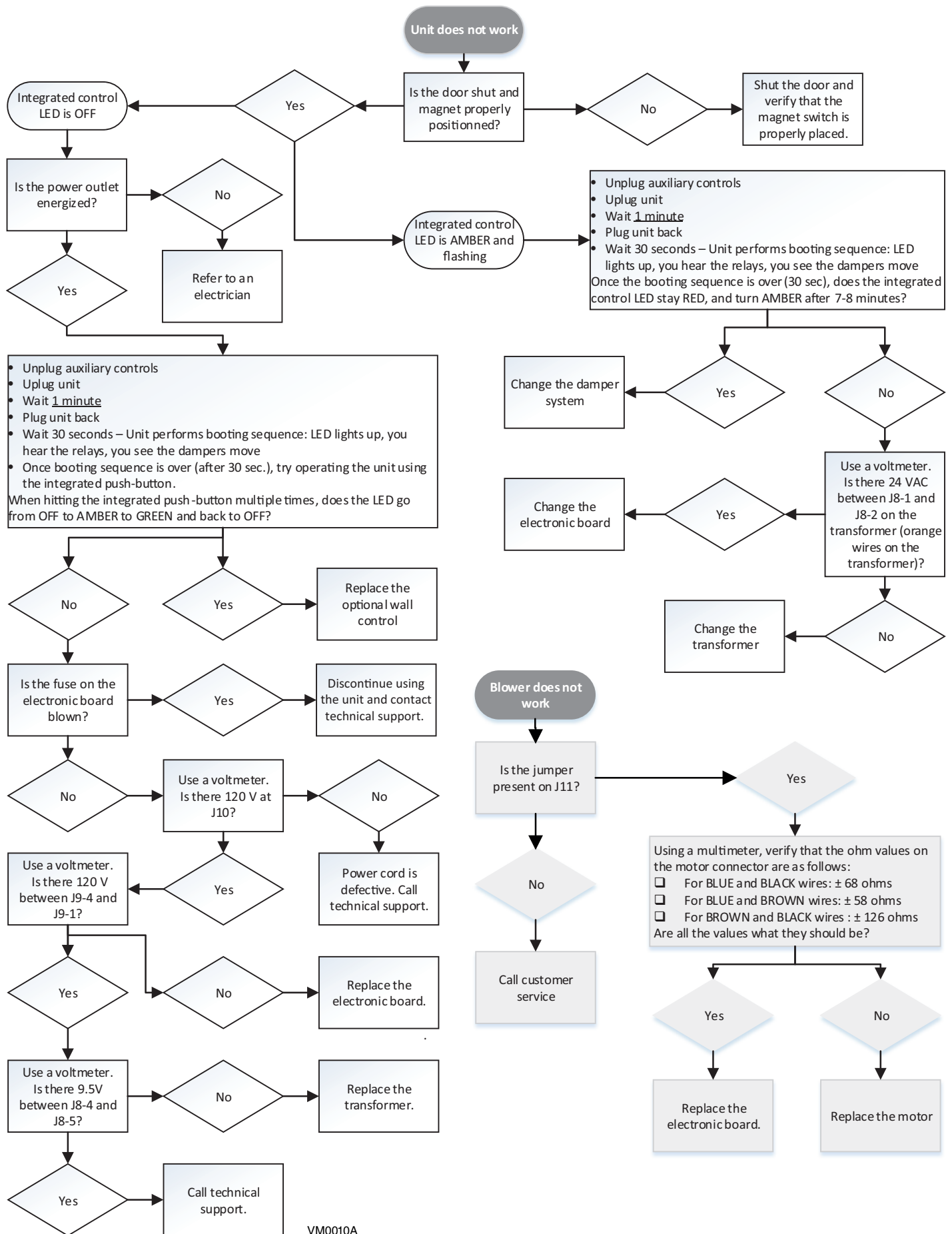

VM0010A

Service technicians only: If you require assistance or have questions after performing the above troubleshooting, call: 1-800-649-0372.