

# 3 AMP / 120 VAC, ELECTRONIC SPEED CONTROL

## WARNING

All electrical work must be done in accordance with local codes, ordinances, or National Electrical Code as applicable. **FOR SAFETY, THIS PRODUCT MUST BE GROUNDED.** If you are unfamiliar with methods of installing electrical wiring, secure the services of a qualified electrician.

Turn off power and lock out service panel before installing, wiring, or servicing this product.

To prevent serious injury from electrical shock or damage to electrical components – **DO NOT WIRE HOT!**

Do not use with impedance protected motor unless specifically designed for use with electronic speed control.

This control may only be used with a thermally protected shaded pole or permanent split capacitor motor with a nameplate rating up to 3.0 AMPS @ 120 VAC.

Warranty is void if miswired.

## INSTALLATION INSTRUCTIONS

**NOTE: ALL ELECTRICAL CONNECTIONS MUST BE IN ACCORDANCE WITH LOCAL CODES, ORDINANCES, OR NATIONAL ELECTRICAL CODE. IF YOU ARE UNFAMILIAR WITH METHODS OF INSTALLING ELECTRICAL WIRING, HAVE A QUALIFIED ELECTRICIAN DO IT FOR YOU.**

1. Turn off power and lock out service panel before wiring the control.
2. Install at least 2½" deep switch box for 14-gauge wire or at least 2¾" deep switch box for 12-gauge wire. Can be installed in either a metal outlet box or a plastic outlet box.
3. Connect cables to switch box and appliance using appropriate connectors. Provide 6" leads inside box and appliance.
4. Make electrical connections following diagram on back. Use wire nuts. Make sure both the control and the appliance are properly grounded.
5. Tuck wires into switch box and fasten the control to box using attached screws.
6. Fasten the switch plate to the control using the short screws from the parts bag.

**WIRING DIAGRAM ON BACK.**

### 3 AMP ELECTRONIC SPEED CONTROL

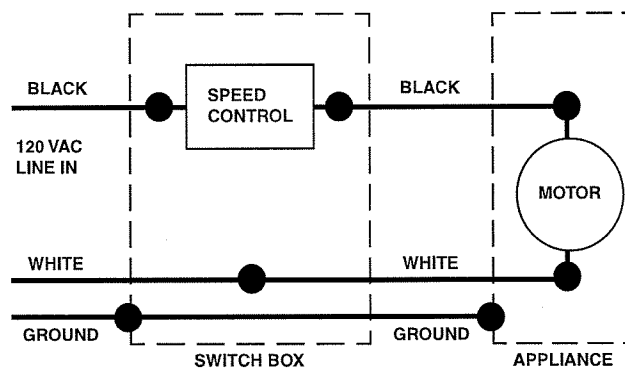

#### BROAN-NUTONE ONE YEAR LIMITED WARRANTY

Broan-NuTone warrants to the original consumer purchaser of its products that such products will be free from defects in materials or workmanship for a period of one year from the date of original purchase. THERE ARE NO OTHER WARRANTIES, EXPRESS OR IMPLIED, INCLUDING, BUT NOT LIMITED TO, IMPLIED WARRANTIES OF MERCHANTABILITY OR FITNESS FOR A PARTICULAR PURPOSE.

During this one-year period, Broan-NuTone will, at its option, repair or replace, without charge, any product or part which is found to be defective under normal use and service.

THIS WARRANTY DOES NOT EXTEND TO FLUORESCENT LAMP STARTERS AND TUBES. This warranty does not cover (a) normal maintenance and service or (b) any products or parts which have been subject to misuse, negligence, accident, improper maintenance or repair (other than by Broan-NuTone), faulty installation or installation contrary to recommended installation instructions.

The duration of any implied warranty is limited to the one-year period as specified for the express warranty. Some states do not allow limitation on how long an implied warranty lasts, so the above limitation may not apply to you.

BROAN-NUTONE'S OBLIGATION TO REPAIR OR REPLACE, AT BROAN-NUTONE'S OPTION, SHALL BE THE PURCHASER'S SOLE AND EXCLUSIVE REMEDY UNDER THIS WARRANTY. BROAN-NUTONE SHALL NOT BE LIABLE FOR INCIDENTAL, CONSEQUENTIAL OR SPECIAL DAMAGES ARISING OUT OF OR IN CONNECTION WITH PRODUCT USE OR PERFORMANCE. Some states do not allow the exclusion or limitation of incidental or consequential damages, so the above limitation or exclusion may not apply to you.

This warranty gives you specific legal rights, and you may also have other rights, which vary from state to state. This warranty supersedes all prior warranties.

To qualify for warranty service, you must (a) notify Broan-NuTone at the address or telephone number below, (b) give the model number and part identification and (c) describe the nature of any defect in the product or part. At the time of requesting warranty service, you must present evidence of the original purchase date.

Broan-NuTone LLC Hartford, Wisconsin www.broan.com 800-558-1711  
Broan-NuTone Canada Mississauga, Ontario www.broan.ca 877-896-1119

99041769E