

# BROAN<sup>®</sup>

## Light Commercial Heat Recovery Ventilators and Energy Recovery Ventilators

---

### Installation, Operation and Service Instructions

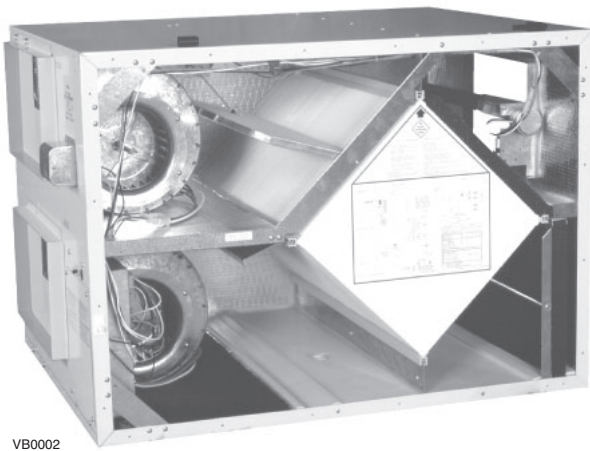

VB0002

**B6LC**

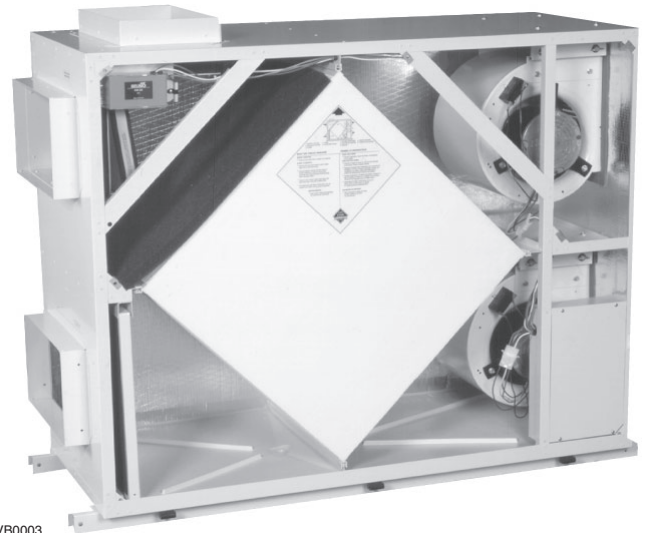

VB0003

**B1600705**

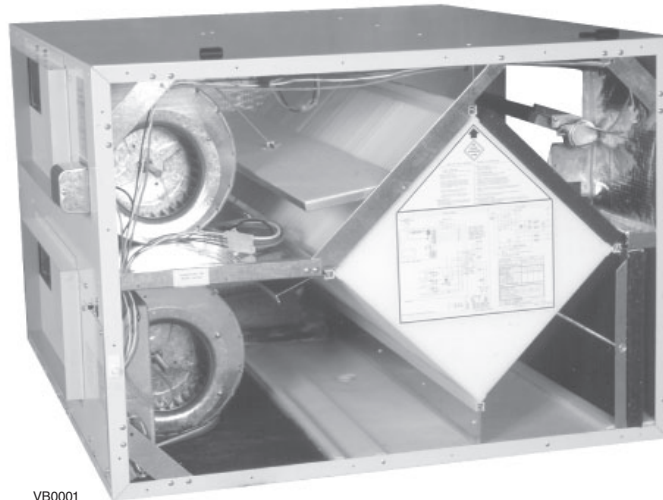

VB0001

**B12LC**

# Table of Contents

1. Safety Considerations . . . . .	2
2. Installation . . . . .	3-4
2.1 Inspection . . . . .	3
2.2 Mounting Location Requirements . . . . .	3
2.3 Mounting Options . . . . .	3
2.4 Ductwork . . . . .	3
2.5 Internal Grilles and diffusers . . . . .	3
2.6 Exterior Hoods . . . . .	4
2.7 Drains . . . . .	4
2.8 Electrical connections . . . . .	4
3. Controls . . . . .	4-5
3.1 General Information . . . . .	4
3.2 Sequence of Operation . . . . .	4
3.3 Defrost . . . . .	5
3.4 Remote Wall Control (Optional) . . . . .	5
4. Airflow Measurements and Balancing . . . . .	5
5. Maintenance and Service . . . . .	5-6
5.1 Bi-Monthly Maintenance . . . . .	5
5.2 Annual Maintenance . . . . .	6
6. Service Parts . . . . .	7-9
6.1 B6LC-B12LC Exhaust Defrost . . . . .	7
6.2 6LC-12LC Recirculation Defrost . . . . .	8
6.3 B1600705 . . . . .	9
Appendix A - Mounting Diagrams . . . . .	10-11
Appendix B - Unit Dimensions . . . . .	12-16
Appendix C - Balancing Dampers Position . . . . .	17
Appendix D - Drain Connections . . . . .	18
Appendix E - Terminal Control Diagrams . . . . .	19-20
Appendix F - Control Box Assembly B6LC and B12LC . . . . .	20
Appendix G - Make-up Heat Requirements . . . . .	21-22
Appendix H - Wiring Diagrams . . . . .	23-27
Appendix I - Troubleshooting . . . . .	28

## 1. Safety Considerations

Hazards may exist within this equipment because it contains electrical and powerful moving components.

Only qualified service personnel should install or service this equipment. Untrained personnel can perform basic maintenance such as maintaining filters.

Observe precautions marked in literature and on labels attached to unit. Follow all safety codes.

### **WARNING**

**Disconnect main power switches to unit before performing service or maintenance. Electric shock can cause personal injury or death.**

## 2. Installation

### 2.1 Inspection

Inspect the exterior of the unit for shipping damage by ensuring that there is no damage to the door, door latches, door hinges, damper, duct collars, cabinet, etc. Inspect the interior of the unit for damage by ensuring that the fan motors and housings, heat or energy recovery cores, insulation, dampers, actuators and drain pans are all intact.

If transportation damage is found, file a claim immediately with the transportation agency. Remove all packaging, tape, etc. from the cabinet.

### 2.2 Mounting Location Requirements

When determining an installation location, the unit must be mounted in a heated area to prevent condensate drain lines from freezing. The mounting location should be away from occupied areas to provide quiet operation. The area should also be easily accessible for maintenance.

#### NOTE:

These units have minimum clearance requirements when mounting. See Appendix B for specific clearance requirements. Mounting options must allow 12" clearance in front of control cover for access.

A mounting location close to an exterior partition will minimize the length of insulated duct. The unit should be close to a drain and 120 volt, 60 Hz power supply. The unit should be mounted away from hot chimneys, electrical panels and other hazards.

### **⚠WARNING**

**It is recommended to wear safety glasses and gloves while performing these instructions.**

### 2.3 Mounting Options

There are several options for hanging or floor mounting the unit.

#### NOTE:

In all cases, the unit must be level. Consult local building code for restrictions in your area regarding installation.

Hang the unit with the reinforced rubber straps provided as shown in Appendix A. Check with local building codes regarding the use of rubber straps in commercial buildings. Attach the straps to the unit with two no. 8 screws provided. Then attach the other end of the strap to the ceiling joists, trusses, custom frame, etc.

The unit can also be hung with 3/8" threaded rod and U channels or angles (not supplied) as shown in Appendix A.

When installing the unit, keep in mind that access to the control panel may be required. Supply and exhaust ducts to outdoors may have 1" to 2" of insulation on them. Rubber vibration isolation may be required and is recommended for quiet operation.

The unit can also be mounted on a metal or wooden curb (not supplied) bolted to the floor as shown in Appendix A. Space must be left under the unit to allow connection of drain lines. A gradual slope is required for the condensate water to drain by gravity (minimum 1/4"/foot). If this is not possible, a pump should be used. If attachment of the unit to the curb is required, ensure that screws, bolts and mounting hardware do not interfere with moving parts or that the integrity of the cabinet insulation is not affected.

### 2.4 Ductwork

The supply and exhaust duct connections on the unit are as follows:

UNIT	DUCT SIZE
B6LC, B1600705	14" x 8" (356 mm x 203 mm)
B12LC	20" x 8" (508 mm x 203 mm)

#### NOTE:

Duct sizes are for connection purposes only. Ducts should be sized to keep noise and pressure drop to a minimum.

The supply and exhaust ducts connected to outdoors, as well as any ducts passing through an unconditioned space, must have a minimum insulation value of R5. In addition, a continuous integral vapor barrier over the duct insulation must be used.

Air balancing dampers are recommended for both supply and exhaust ducts to allow for adjustment of airflow. Also, flexible canvas connectors should be installed close to the unit in the supply duct to the building and the exhaust duct from the building to reduce noise transmission from the unit to the building, see Appendix C.

All ports on the B6LC and B12LC units have 1" flanges to facilitate the installation of the ductwork. Please note that the "Fresh Air from Outdoors" port has a defrost damper incorporated with it.

Ensure that any mechanical fasteners used to connect the duct do not interfere with the operation of the damper. **Screws can be installed on the side of the cabinet rather than the flange for this port only.** For port locations see Appendix B.

All ports on the B1600705 unit have 2" flanges to facilitate the installation of the ductwork. Please note the "Fresh Air From Outdoors" connection is factory set to be the left side upper port. It is possible to reverse the operation of the defrost damper in order to use the port on top of the cabinet for "Fresh Air From Outdoors" connection.

To change the «Fresh Air From Outdoors» from the side to the top use the following directions. For port locations see Appendix B.

Remove the cover of the damper motor with a flat screwdriver. Reverse the ORANGE and RED wires by moving the ORANGE from terminal no. 2 to terminal no. 3 and moving the RED wire from terminal no. 3 to terminal no. 2. The end result in order to have the "Fresh Air From Outdoors" connection to the top port will be: no. 1 - WHITE, no. 2 - RED, no. 3 - ORANGE.

### 2.5 Internal Grilles and Diffusers

Locate exhaust grilles and supply diffusers to provide effective ventilation and avoid short circuiting of airflows. Adjustable dampers should be provided at every grille and diffuser location to make balancing of the system possible.

A proper selection of style and size of grilles and diffusers is required to minimize pressure drop. The velocity of the airflow should not exceed 400 ft./min. for normal applications.

The duct system should be designed according to the high speed flow rate of the unit. In order to keep the noise and pressure drop to a minimum, a maximum air velocity of 1100 ft/min. should be used in calculations in duct design. The duct runs should be kept as short as possible with the minimum amount of elbows and transitions.

The manufacturer recommends the use of smooth radius elbows or square elbows with turning vanes to achieve maximum performance.

## 2. Installation (cont'd)

### 2.6 Exterior Hoods

It is important that the fresh air intake hood be positioned well away from any source of contamination. The exterior supply and exhaust hoods must be separated enough to prevent cross-contamination and at an elevation that will prevent blockage by snow, dirt and leaves.

#### NOTE:

Consult local building code for restrictions in your area.

A rodent screen with 1/4" mesh must be installed to prevent the intake of large debris and animals. A backdraft damper may need to be installed in the exhaust duct to prevent cold air entering the building if the unit is to be shut off for a long period of time.

To maintain optimum airflow performance, exterior hood selection must be such that the minimum free area of opening is 140 inches<sup>2</sup>.

### 2.7 Drains

The drain fittings provided with the unit will accept a 3/4" NPT coupler (supplied by others). The drain line for the unit must be fabricated on-site and connected to the building main. A loop in the hose or trap in the copper or plastic pipe must be provided to prevent sewer gases from entering the unit when connecting to a drain as illustrated in Appendix D.

#### NOTE:

Consult local building code for plumbing requirements in your area. If copper pipe is to be used, ensure not to solder to the 3/4" coupler while it is attached to the plastic drain fitting as deformation may occur. Ensure adequate slope is present to allow good drainage (minimum 1/4" per foot).

### 2.8 Electrical Connections

#### POWER

A terminal block and strain relief bushing or a junction box is provided for line voltage to make the necessary power connections.

The electrical requirements are as follows:

	B6LC	B1600705	B12LC
VOLTAGE	120 V	120 V	120 V
MCA	9.50 A	6.63 A	14.30 A
MOP	12.00 A	9.13 A	20.00 A

## 3. Controls

### 3.1 General Information

#### FAN INTERLOCK RELAY OUTPUT (FF)

External fan control can be achieved by connecting an external 24 volts fan control through dry contacts (FF). These contacts are closed on a call for ventilation or defrost. See wiring diagram shown in Appendix E.

#### SPEED SELECTION (6LC /12LC UNITS ONLY)

There are three speed settings available with the controls, only two of which can be functional at any one time. The units are factory set to use the low and high speed taps on the blower motors. If necessary, the medium speed tap can be used instead of the low speed tap. See wiring diagrams for instructions on how to make this change. Units without the remote wall control option can be shut off by opening the contact between LOW - COM or HIGH - COM as shown in Appendix E-2.

### 3.2 Sequence of Operation

Before start-up, check the unit for obstructive packaging, objects near or in blowers, dampers, heat exchangers, etc. Once installation is complete, check all modes of operation to ensure that the unit is working properly. Close the doors and check for operation on LOW, COM and HIGH. Use a wall control or the dry contact switching to run fan speeds as shown in Appendix E-2.

The B1600705 unit is two speed. Low speed can be initiated by creating a closure across LOW - COM or high speed can be initiated by creating a closure across HIGH - COM.

#### UNIT CHECK POINTS (ALL UNITS):

- Power connected, no ventilation call - Both fans are off, defrost damper (if equipped) closes off fresh air from outdoors.
- Power connected, low speed call - Both fans on low speed internal defrost damper (if equipped) opens fresh air from outdoors. For B6LC and B12LC units only, if equipped with recirculation module, the internal defrost damper closes recirculation opening.
- Power connected, high speed call - Both fans on high speed, defrost damper opens fresh air from outside. For B6LC and B12LC units only, if equipped with recirculation module, the internal defrost damper closes recirculation opening.
- Power connected, occupied timer/sensor connection open (unoccupied mode) - Both fans are off, defrost damper closes fresh air from outdoors. For B6LC and B12LC units only, if equipped with recirculation module, the internal defrost damper opens recirculation opening.
- Power connected, FF control contacts close during unit ventilation or defrost cycle.

### 3. Controls (cont'd)

#### 3.3 Defrost

The unit functions are controlled by integrated controls in the unit which may include Exhaust Only Defrost or Recirculation Defrost (via the recirculation module - B6LC and B12LC units only). In cold temperatures, defrost cycles will remove frost from the recovery cores to maintain good operation.

##### EXHAUST ONLY DEFROST (OPTIONAL)

Frost removal occurs when the supply blower de-energizes, the supply air damper and the core damper close and the exhaust fan continues to circulate only warm inside air through the heat recovery core to maintain ventilation. This process prevents the build up of ice in the core. Defrost is temperature initiated at 23°F to -22°F and time based.

#### ⚠ WARNING

**A negative building pressure may develop during the defrost cycle with possible backdrafting fumes from combustion equipment.**

##### RECIRCULATION DEFROST MODULE (OPTIONAL - FACTORY INSTALLED)

The Recirculation Defrost Module is only available with the B6LC and B12LC units. The defrost cycle is electronically controlled in response to the outdoors temperature 23°F to -22°F. On a call for defrost, the supply air damper in the recirculation module closes, exhaust fan is de-energized and the supply fan continues to recirculate warm air through the heat recovery core or energy recovery core. It is possible to extend the defrost times during very cold weather by removing the jumper JU1-F on the circuit board as shown in Appendix F. For dimension and weight changes to the B6LC and B12LC models with recirculation defrost, see Appendix B-2 and B-4.

#### 3.4 Remote Wall Control (Optional)

Remote mounted wall control options can be used to control the ventilators from a location remote to the installed unit location. The connection from the ventilator to the control is low voltage and requires a 4 conductor (24 ga. minimum) LVT cable. Models are available with a dehumidistat control. The following two options are available.

##### SLIDE SWITCH TYPE

Dehumidistat to engage high speed exchange. Slide switch operation supporting continuous low exchange and continuous high exchange.

##### VT10W (FOR B1600705 UNIT ONLY)

Ideal for pool dehumidification. Dehumidistat to engage high speed exchange. Push-button operation supporting: intermittent (stand-by) ventilation, continuous low exchange, continuous high exchange, maintenance indicator light and exchange indicator light.

### 4. Airflow Measurement and Balancing

Once installation is complete, the supply and exhaust airflows should be balanced. This will ensure proper operation and a good quality installation.

A well designed duct system with properly sized duct runs and equal static pressure losses of both the supply and exhaust will aid in balancing the unit. However, it will be necessary to take flow measurements with the proper equipment to ensure a balanced system.

Before proceeding with balancing, all windows, overhead doors and walk-in doors should be closed and exhaust systems should be turned off.

### 5. Maintenance and Service

#### 5.1 Bi-Monthly Maintenance

#### ⚠ WARNING

**Disconnect power before maintaining unit.**

Bi-monthly maintenance should include:

##### AIR FILTERS

The standard foam filters are washable. Under normal conditions it is recommended that they be cleaned every two months. More frequent cleaning may be required under extremely dirty operating conditions. Use a vacuum cleaner to remove the heaviest portion of accumulated dirt, then wash with warm water.

A medium efficiency filter for the supply air stream is available from your supplier. This filter is disposable and should be replaced when it becomes dirty.

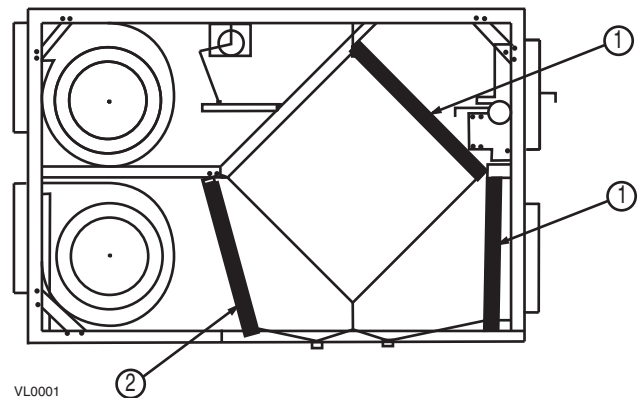

##### B6LC and B12LC units

- ① Washable foam filter
- ② MEF filter - optional

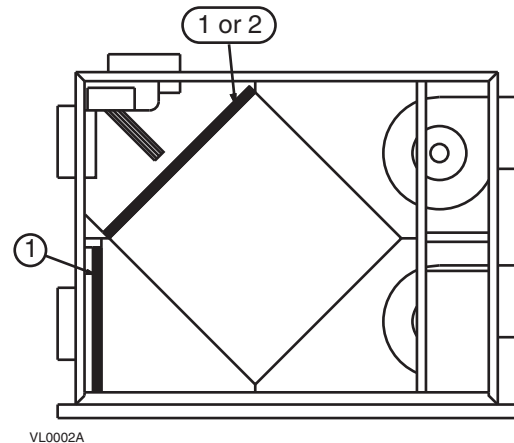

##### B1600705 unit

##### DRAIN PANS AND INTERIOR OF UNIT

With the filters removed from the unit, the foil faced insulation surfaces and the drain pans should be wiped clean with a soft cloth and mild cleaning solution. Also ensure that the drain fittings are free from dirt and are draining freely.



## 5. Maintenance and Service (cont'd)

### ⚠ WARNING

**Disconnect power before maintaining unit.**

#### 5.2 Annual Maintenance

Annual maintenance should include:

##### AIR FILTERS

Vacuum and wash standard foam filters. Replace medium efficiency filter if present.

##### DRAIN PANS AND INTERIOR OF UNIT

Wash the foil faced insulation surfaces and wipe the drain pans with a soft cloth and mild cleaning solution. Check the drain fittings to ensure they are draining freely.

##### HEAT RECOVERY CORE

The heat recovery core must be handled with care. It is recommended that it be washed once a year following the season of most intense use, in order to ensure maximum efficiency of the partitions.

Allow the heat recovery core to soak for three hours in warm water and mild soap. Rinse under a heavy stream of water.

### CAUTION

**Hot water and a strong cleaning agent could damage the polypropylene core. Ensure the core is reinstalled in the unit in the correct orientation. Use the sticker as a guide.**

##### ERV HM CORE

### CAUTION

**Do not soak the ERV HM core in water. This core can easily be damaged especially if it is soaked.**

For ERV HM core, use a vacuum cleaner or low pressure air jet. It is not recommended to use solvents or detergents as these may damage the media or structure of the core.

##### FANS

Blower wheels and fan housing should be checked for dirt build-up. If they appear dirty, it may be necessary to remove the blower assembly and then vacuum the dust out through the fan mouth. See next column for instructions on removing the blower assembly.

##### SYSTEM OPERATION CHECK

Verification of all control modes should be checked to ensure proper operation. Refer to 3.2 Sequence of Operation section.

##### TESTING AND REPLACEMENT OF THE DAMPER ACTUATOR

Check damper operation by switching between LOW - COM or HIGH - COM on the dry contact terminal or by switching through the modes on the optional remote wall control. If the damper does not respond in one or both directions, check all connections.

**7000 unit ONLY:** Check for 24 volt output between the WHITE/RED and the WHITE/ORANGE wires at the damper motor. If 24 volts can be measured at the damper motor, the problem is either in the connections, the defrost relay or the main circuit board.

**6LC/12LC units ONLY: (CAUTION: 120 VAC)** Check for 120 volt output across the WHITE/BLACK wires. If 120 volts can be measured at the motor, replace the motor. If 120 volts cannot be measured at the motor, check pins J1-9 at the printed circuit board.

##### MAIN CIRCUIT BOARD REPLACEMENT

The main circuit board must be replaced if an electronic problem arises.

For example, the unit suddenly stops, the unit stays in defrost all of the time or if control functions are not working properly.

Ensure that power is reaching the board. Test the blower motors and damper actuators for operation when directly connected to the appropriate power voltage. If the motor and damper actuators function normally, replace the main circuit board.

##### MOTOR AND BLOWER REMOVAL AND INSTALLATION

Disconnect power from the unit. To determine if the fan motor is burned out, disconnect the four-wire service connector between the motor and cabinet. Connect the motor directly to a 115 volts power source with an electrical cable, as follows:

RED + WHITE	Low speed
BLUE + WHITE	Medium speed
BLACK + WHITE	High speed

If the motor functions normally, there is a problem with the wiring connections or the main circuit board. Check all wiring and replace main circuit board if necessary.

If the blower does not run, it must be replaced. To replace the motor, remove the recovery core or energy recovery core from the unit. Disconnect the four-wire service connector from the unit. Remove the fasteners holding the motor assembly in place. Lift the assembly up and out, using one hand under the motor and one hand to steady it. Remove the assembly carefully from the unit to avoid damage to the insulation, shelf, etc. Install the repaired motor assembly by following these instructions in reverse.

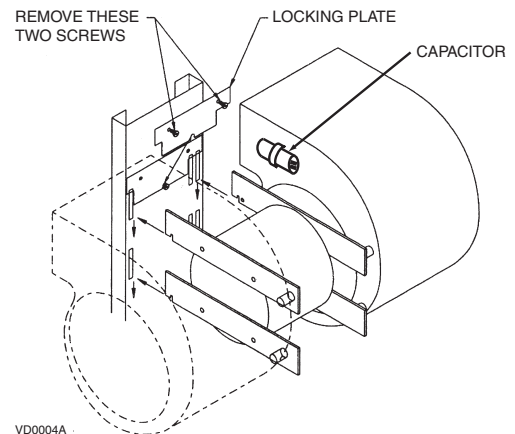

#### B6LC and B12LC units

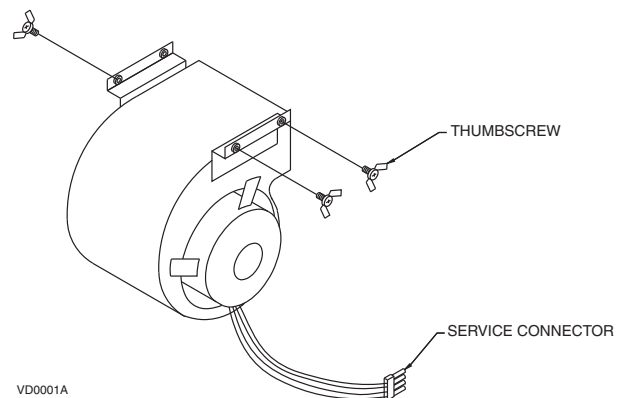

#### B1600705 unit

## 6. Service parts

### 6.1 B6LC-B12LC Exhaust Defrost

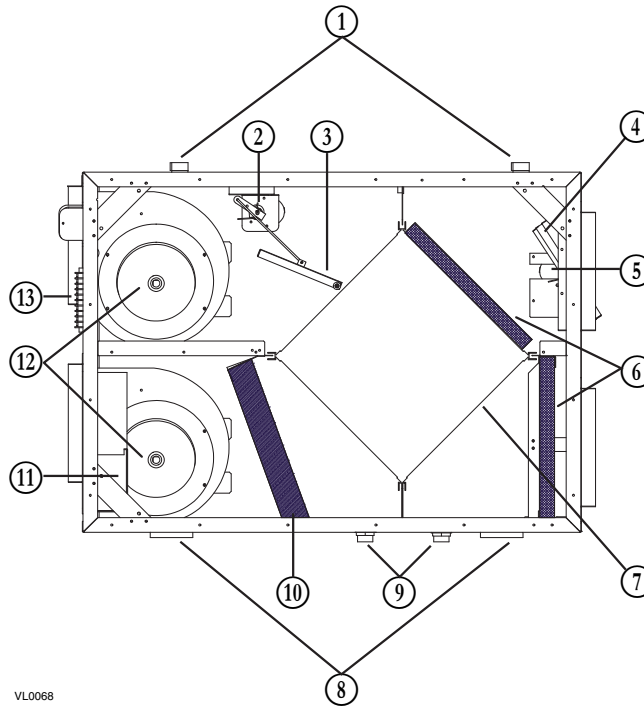

VL0068

Ref.	Part No.	Description
①	SV13036	Hinge kit (male-female)
②	SV1808139	Core Defrost Actuator B6LC-B12LC
	SV63341	Core Defrost Actuator B12LC, Powder Coated
③	SV63327	Core Damper B6LC
	SV63328	Core Damper B12LC
	SV63329	Core Damper B12LC, Powder Coated
④	SV201982	Fresh Air Damper B6LC
	SV63330	Fresh Air Damper B12LC
	SV63331	Fresh Air Damper B12LC, Powder Coated
⑤	SV1808138	Fresh Air Damper Actuator B6LC-B12LC
	SV63332	Fresh Air Damper Act. B12LC Powder Coated
⑥	SV201805	Filter SWF 13.125" x 11.25" x 1" (unitary)
⑦	SV1808147	Core Poly B6LC-B12LC (unitary)
	SV1604191	Core Aluminum B6LC-B12LC (unitary)
	SV1607787	ERV HM Core B6LC-B12LC (unitary)
⑧	SV16035	Door Latch-Keeper Kit
⑨	SV1607456	Drain Fitting B6LC, B12LC, B1600705 (unitary)
⑩	SV63342	Filter Optional MERV 8, B6LC, B12LC (unitary)

Ref.	Part No.	Description
⑪ *	SV1808130	PCB Electronic B6LC, B12LC, B1600705
	SV202382	Thermistor B6LC, 1B2LC, B1600705
	SV500025914	Relay SPDT 120 VAC, 1 HP, 30 A @ 120 VAC, B6LC, B12LC
	SV500025915	Relay DPST 120 VAC, 1 HP, 30 A @ 120 VAC, B6LC, B12LC
⑫	SV1808144	Blower Ass'y B6LC
	SV1808148	Blower Ass'y B12LC
	SV1808148P	Blower Ass'y B12LC Powder Coated Option
	SV1808142	Blower Wheel B6LC, B12LC (not shown)
	SV1808149	Fan Motor B6LC (not shown)
	SV1808150	Fan Motor B12LC (not shown)
⑬	SV63110	Capacitor 5 µF LC, B1600705 (not shown)
	SV208507	Terminal Strip 10-Pin Molex 38721-6710, B6LC, B12LC
*	SV63571	Door Assembly B6LC, B12LC
*	SV63572	Door Assembly B12LC (Powder Coated Option)
*	SV1808145	Accessories kit B6LC, B12LC
*	SV63344	Hanger Strap 18" Kit B6LC, B12LC, B1600705

\* Not Shown.

**NOTE:** ② and ③ not available for ERV HM Core

**NOTE 2:** ⑦ 2 cores required for B6LC unit  
3 cores required for B12LC unit

**NOTE 3:** ⑥ 4 filters for B6LC unit  
6 filters for B12LC unit

**NOTE 4:** ⑩ 2 filters for B6LC unit  
3 filters for B12LC unit

## 6. Service parts (cont'd)

### 6.2 B6LC-B12LC Recirculation Defrost

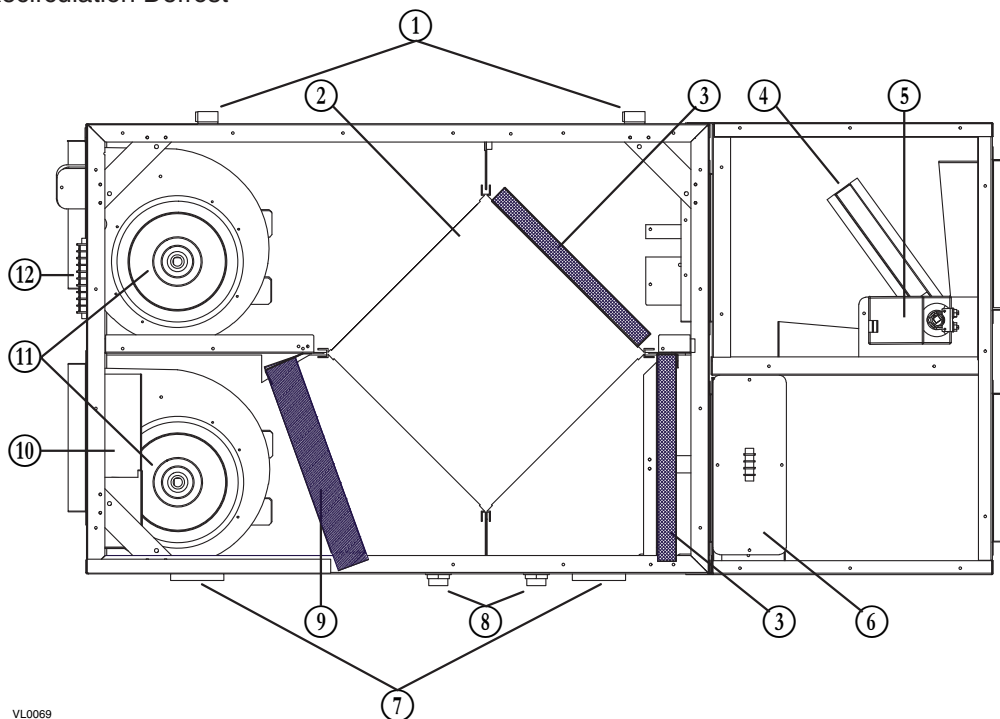

VL0069

Ref.	Part No.	Description
①	SV13036	Hinge kit (male-female)
②	SV1808146	Core Poly UL B6LC-B12LC (unitary)
	SV1604191	Core Aluminum B6LC-B12LC (unitary)
	SV1607787	ERV HM Core B6LC-B12LC (unitary)
③	SV201805	Filter SWF 13.125" x 11.25" x 1" (unitary)
④	SV63333	Recirculation Damper B6LC
	SV63334	Recirculation Damper B12LC
	SV63335	Recirculation Damper B12LC, Powder Coated
⑤	SV225855	DamperMotorBelimoLMB24-3-T,B1600705, B6LC-B12LC (Recirculation Defrost Option)
⑥ *	SV066161	Fuse Holder B6LC, B12LC, B1600705
	SV201603	Terminal Strip 3-Pin Molex 38721-6703 B6LC, B12LC (Recirculation Defrost)
	SV63352	Relay DPDT 24VAC, 1/2 HP, 15A @ 120VAC, B6LC, B12LC (Recirculation Defrost Option)
	SV066176	Fuse 0.25 A, 250 V Time Delay 1.25" MDL B6LC-B12LC (Recirculation Defrost Option)
	SV500025914	Relay SPDT 120 VAC, 1 HP, 30 A @ 120 VAC, B6LC, B12LC
	SV64098	Transformer 120-24V 40VA
⑦	SV16035	Door Latch-Keeper Kit
⑧	SV1607456	Drain Fitting B6LC, B12LC, B1600705 (unitary)
⑨	SV63342	Filter Optional MERV 8, B6LC, B12LC (unitary)

Ref.	Part No.	Description
⑩ *	SV1808130	PCB Electronic B6LC, B12LC, B1600705
	SV202382	Thermistor B6LC, B12LC, B1600705
	SV500025914	Relay SPDT 120 VAC, 1 HP, 30 A @ 120 VAC, B6LC, B12LC
	SV500025915	Relay DPST 120 VAC, 1 HP, 30 A @ 120 VAC, B6LC, B12LC
⑪	SV1808144	Blower Ass'y B6LC
	SV1808148	Blower Ass'y B12LC
	SV1808148P	Blower Ass'y B12LC Powder Coated Opt.
	SV1808142	Blower Wheel B6LC, B12LC (not shown)
	SV1808149	Fan Motor B6LC (not shown)
	SV1808150	Fan Motor B12LC (not shown)
⑫	SV63110	Capacitor 5 μF LC, B1600705 (not shown)
	SV208507	Terminal Strip 10-Pin Molex 38721-6710, B6LC, B12LC
*	SV63571	Door Assembly B6LC, B12LC
*	SV63572	Door Assembly B12LC (Powder Coated Option)
*	SV1808145	Accessories kit B6LC, B12LC
*	SV63344	Hanger Strap 18" Kit B6LC, B12LC, B1600705
*	SV64228	Backdraft damper B6LC recirculation
*	SV64229	Backdraft damper B12LC recirculation

\* Not Shown.

**NOTE 3:** ⑨ 2 filters for B6LC unit  
3 filters for B12LC unit

**NOTE 1:** ② 2 cores required for B6LC unit  
3 cores required for B12LC unit

**NOTE 2:** ③ 4 filters for B6LC unit  
6 filters for B12LC unit



## 6. Service parts (cont'd)

### 6.3 B1600705

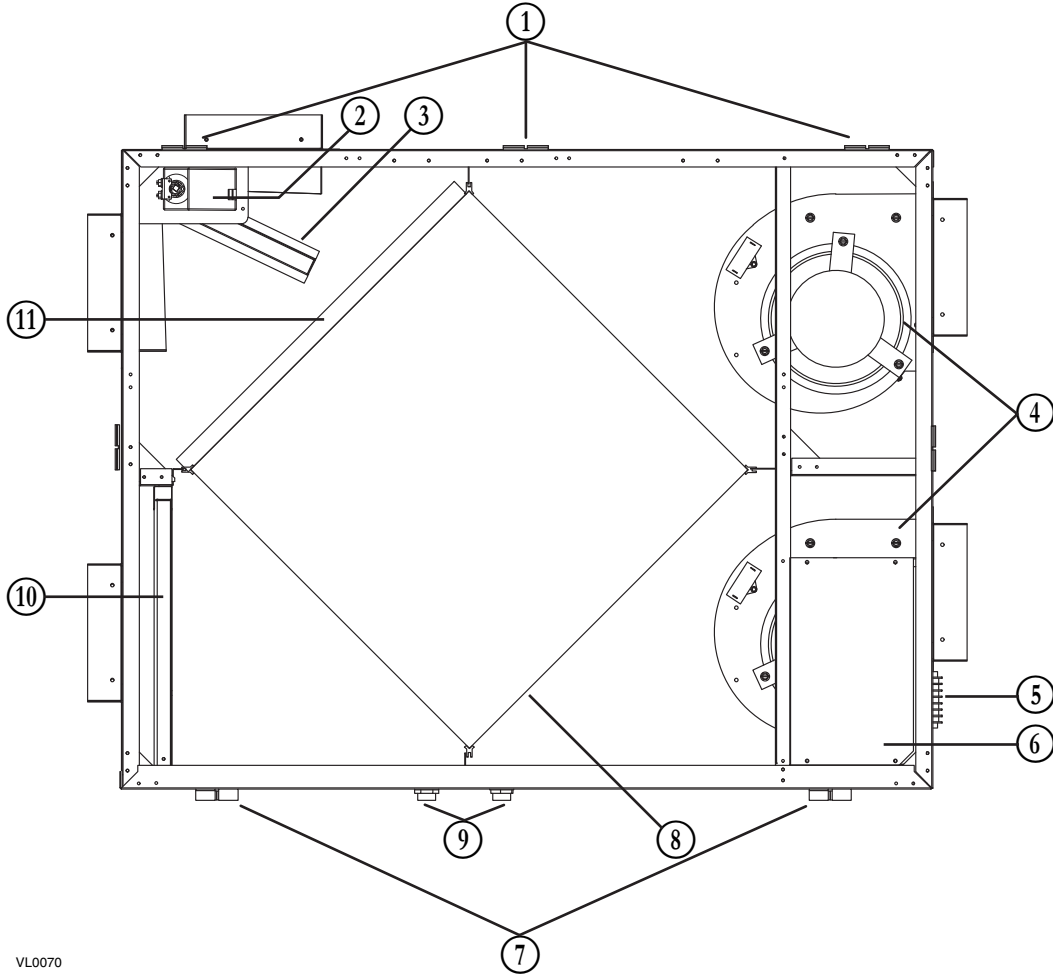

VL0070

Ref.	Part No.	Description
①	SV16035	Door Latch-Keeper kit
②	SV225855	Damper Motor Belimo LMB24-3-T, B1600705, B6LC-B12LC (Recirculation Defrost Option)
③	SV1604178	Fresh Air Damper
④	SV1604168	Blower Ass'y B1600705
	SV1604177	Blower Wheel (not shown)
	SV1604169	Fan Motor B1600705 (not shown)
	SV63110	Capacitor 5 $\mu$ F LC, B1600705 (not shown)
⑤	SV202790	Terminal Strip 7-Pin Molex 38721-6707, B1600705
⑥ *	SV1808130	PCB Electronic B6LC, B12LC, B1600705
	SV202382	Thermistor B6LC, B12LC, B1600705
	SV63117	Transformer B1600705
	SV63345	Relay DPDT 120VAC, 1/2HP, 15A @ 120VAC, B1600705, B6LC, B12LC
	SV066161	Fuse Holder B6LC, B12LC, B1600705
	SV066169	Fuse 0.5 A, 250 V Time Delay 1.25" MDL B1600705

Ref.	Part No.	Description
⑦	SV13036	Hinge Kit (male-female)
⑧	SV1604156	Core Poly B1600705
⑨	SV1607456	Drain Fitting B6LC, B12LC, B1600705 (unitary)
⑩	SV134147	Filter SWF 18.6" x 15.6" x 1" B1600705 Exhaust (unitary)
⑪	SV134145	Filter SWF 19" x 22.75" x 1" B1600705 Supply (unitary)
*	SV1608701	Optional MERV 7, Filter B1600705 Supply (unitary)
*	SV63573	Door Ass'y B1600705 (Powder Coated Option)
*	SV027123	Anti-vibration Bushing B1600705 (unitary)
*	SV63344	Hanger Strap 18" Kit B6LC, B12LC, B1600705

\* Not Shown.

# Appendix A

## MOUNTING DIAGRAMS

### B6LC AND B12LC UNITS

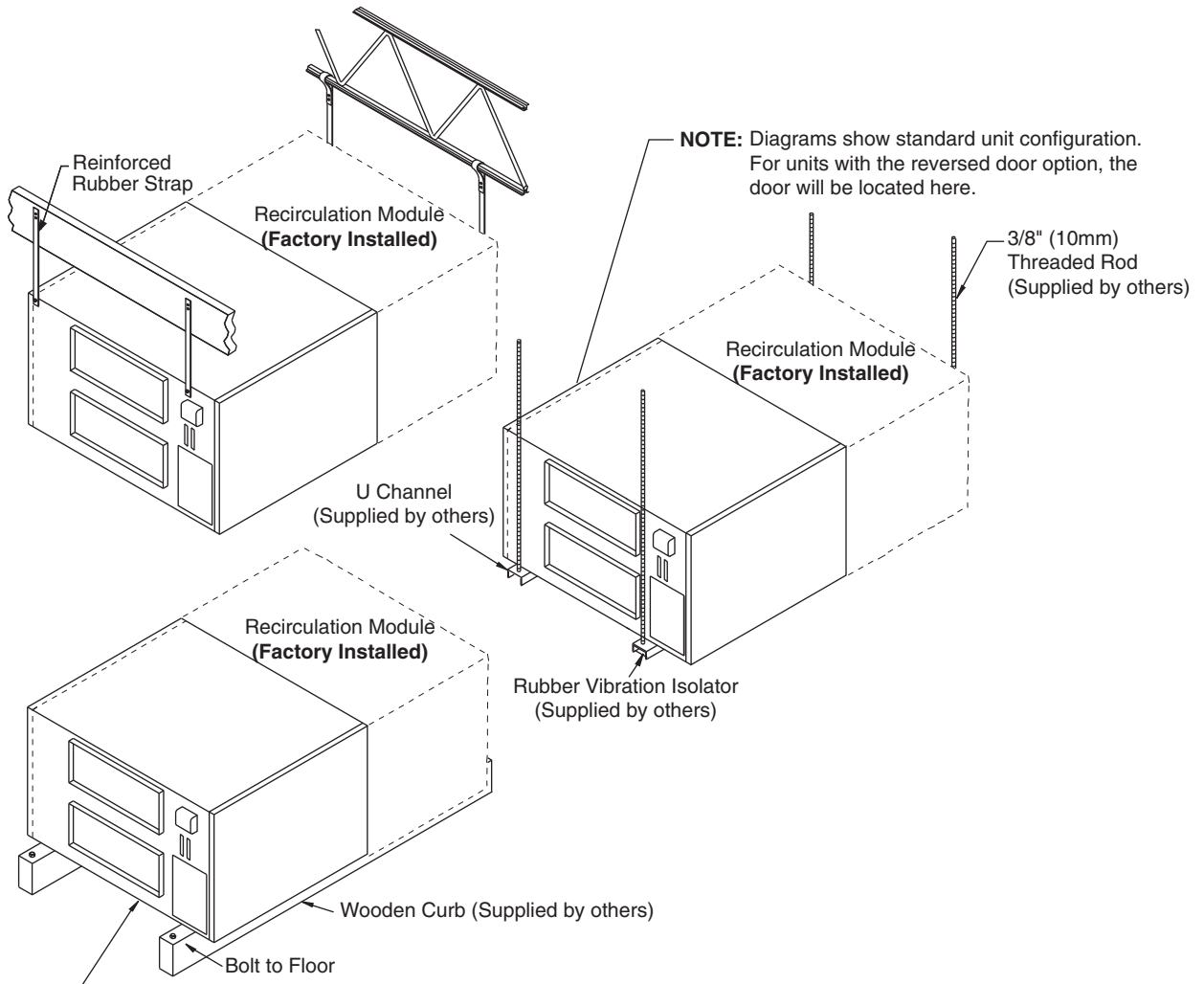

Space must be left to allow connection of drain lines with adequate slope for drainage

VD0002A

# Appendix A

## MOUNTING DIAGRAMS

### B1600705 UNIT

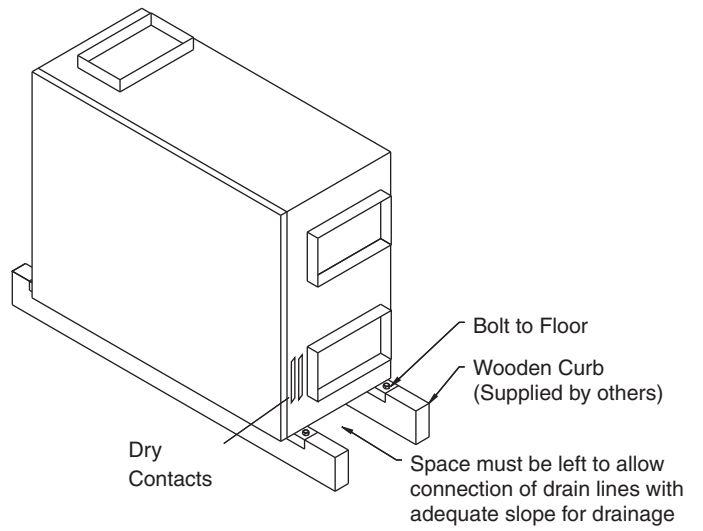
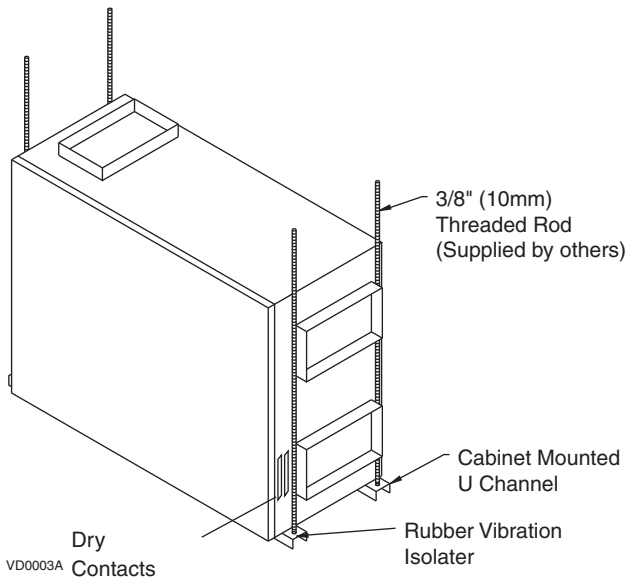

# Appendix B

## UNIT DIMENSIONS

### B-1: B6LC (WITHOUT RECIRCULATION MODULE)

NOTES:  
 Center of gravity  
 Direction of airflow

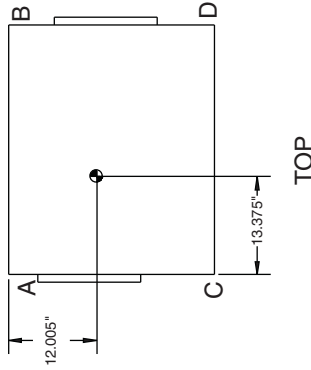

B6LC POLY CORE		B6LC ALUMINUM CORE		B6LC ERV HM CORE	
PTS	LB.	Kg	PTS	LB.	Kg
A	38.49	17.45	A	44.21	20.00
B	24.96	11.32	B	28.67	13.00
C	51.29	23.26	C	58.92	26.72
D	33.26	15.08	D	38.21	17.30
TOTAL	148.00	67.13	TOTAL	170.00	77.11
			TOTAL	156.96	72.60

CONNECTION TABLE	
CONNECTION SIZES	
(A)	14 Gauge wire nut
(B)	Condensate drain fitting (2 x) 3/4" NPT

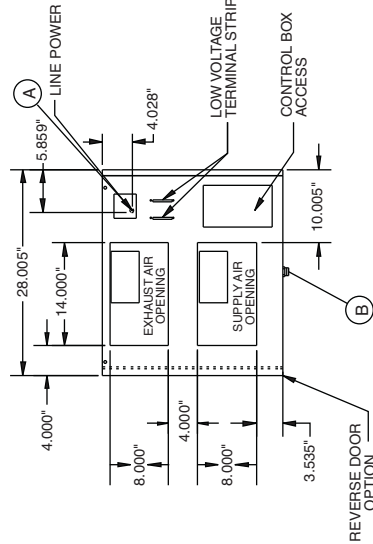

LEFT SIDE

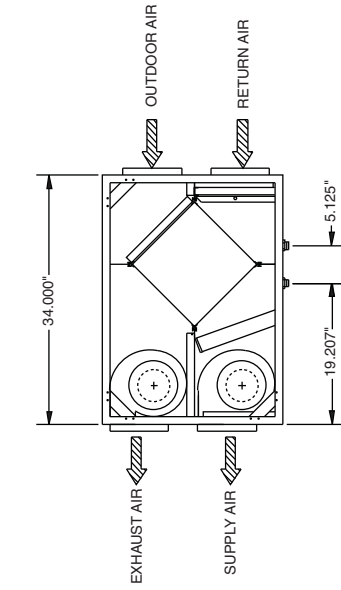

FRONT

NOTE: FOR UNITS WITH THE REVERSED DOOR OPTION, INTERIOR COMPONENTS WILL APPEAR AS A MIRROR IMAGE OF THE ABOVE DIAGRAM.

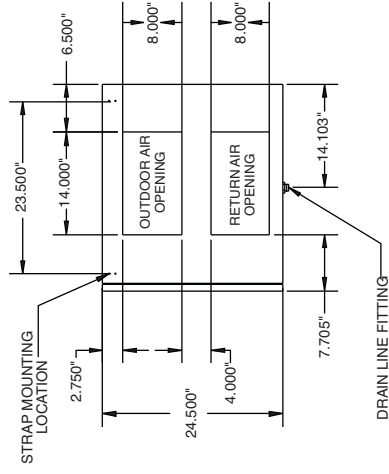

RIGHT SIDE

NOTE: THIS MODEL HAS A DAMPER LOCATED ON THE OUTDOOR INTAKE CONNECTION. THIS DAMPER WILL CLOSE DURING A DEFROST CYCLE OR WHEN THE UNIT IS PLACED IN THE 'OFF' POSITION WITH POWER MAINTAINED TO THE UNIT. THIS DAMPER IS NOT DESIGNED AS A BACKDRAFT DAMPER AND WILL REMAIN OPEN IF POWER IS DISCONNECTED FROM THE UNIT FOR ANY REASON.

A MINIMUM OF 12.000" CLEARANCE FROM ANY OBSTRUCTION IS REQUIRED FOR REMOVAL OF CONTROL BOX.

A MINIMUM OF 15.000" CLEARANCE FROM ANY OBSTRUCTION IS REQUIRED FOR REMOVAL OF HEAT RECOVERY CORES, FANS, ETC. THE ACCESS DOOR CAN BE REMOVED FROM CABINET WITH ONLY 2.000" OF CLEARANCE.

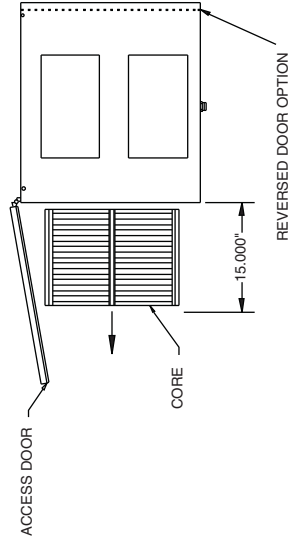
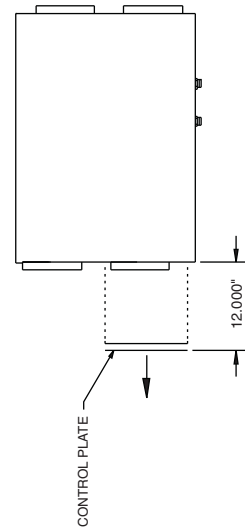

# Appendix B (cont'd)

## UNIT DIMENSIONS

### B-2: B6LC WITH RECIRCULATION MODULE (FACTORY INSTALLED)

B6LC POLY CORE with recirculation module		B6LC ALUMINUM CORE with recirculation module		B6LC ERV-HM CORE with recirculation module	
PTS	LB.	PTS	LB.	PTS	LB.
90	197	105	231	105	206
TOTAL		TOTAL		TOTAL	

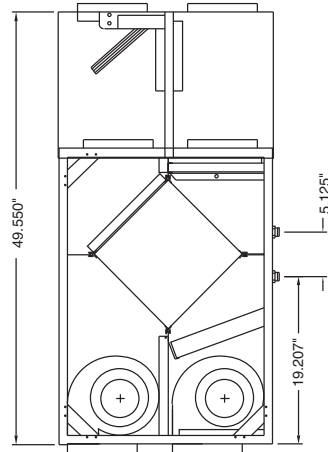
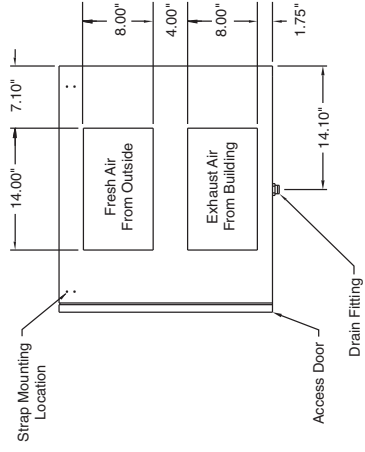

NOTE:  
For units with the reversed door option, interior components will appear as a mirror image of the above diagram.

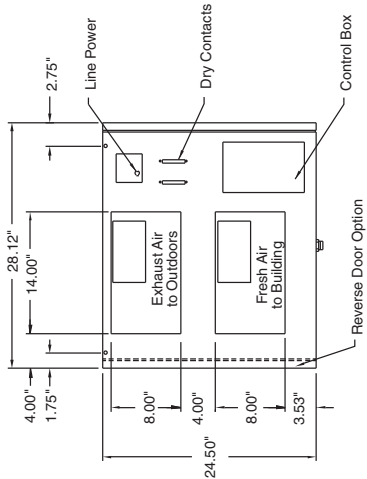

A minimum of 15.00" clearance from any obstruction is required for removal of heat recovery cores, fans, etc.  
The access door can be removed from cabinet with only 2.00" of clearance.

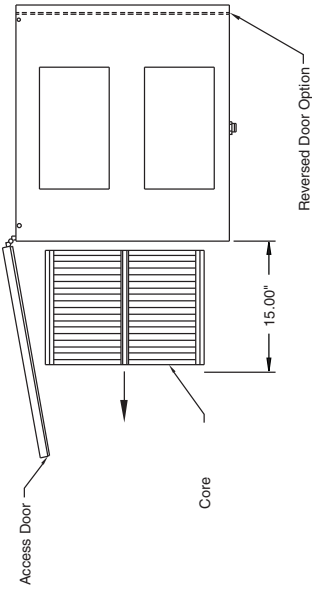

A minimum of 12.00" clearance from any obstruction is required for removal of control box.

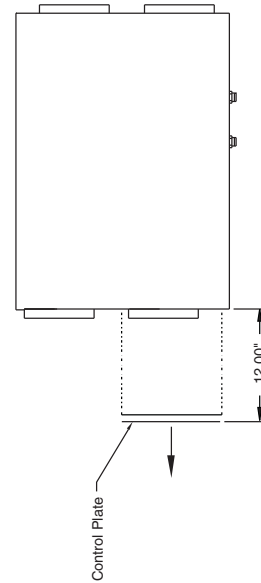



# Appendix B (cont'd)

## UNIT DIMENSIONS

### B-3: 12LC (WITHOUT RECIRCULATION MODULE)

**NOTES:**

- Center of gravity
- ⇒ Direction of airflow

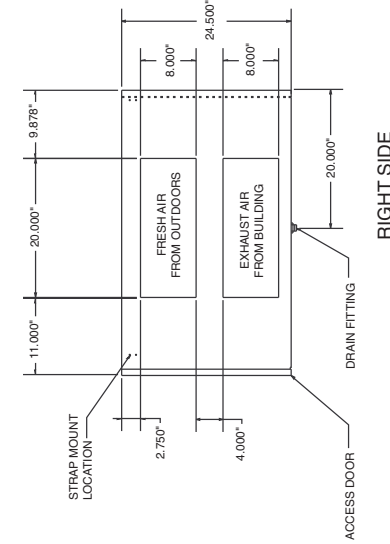
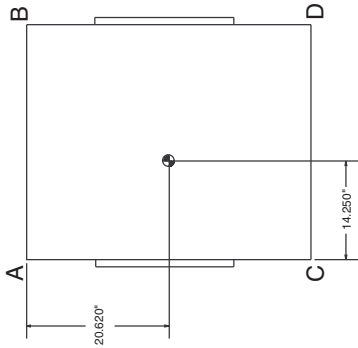

**RIGHT SIDE**

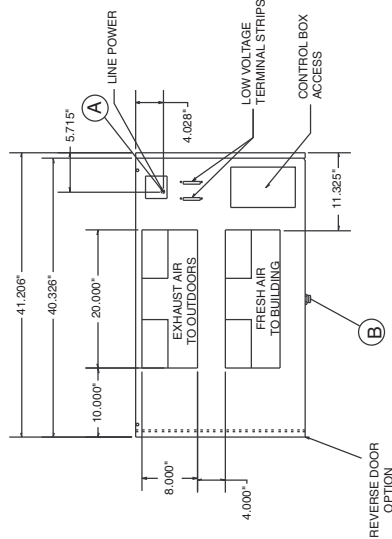

**LEFT SIDE**

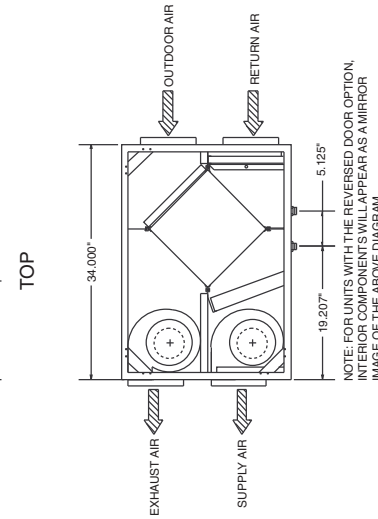

**FRONT VIEW**

**NOTE:** THIS MODEL HAS A DAMPER LOCATED ON THE OUTDOOR INTAKE CONNECTION. THIS DAMPER WILL CLOSE DURING A DEFROST CYCLE OR WHEN THE UNIT IS PLACED IN THE 'OFF' POSITION WITH POWER MAINTAINED TO THE UNIT. THIS DAMPER IS NOT DESIGNED AS A BACKDRAFT DAMPER AND WILL REMAIN OPEN IF POWER IS DISCONNECTED FROM THE UNIT FOR ANY REASON.

A MINIMUM OF 12.000" CLEARANCE FROM ANY OBSTRUCTION IS REQUIRED FOR REMOVAL OF CONTROL BOX.

A MINIMUM OF 15.000" CLEARANCE FROM ANY OBSTRUCTION IS REQUIRED FOR REMOVAL OF HEAT RECOVERY CORES, FANS, ETC. THE ACCESS DOOR CAN BE REMOVED FROM CABINET WITH ONLY 2.000" OF CLEARANCE.

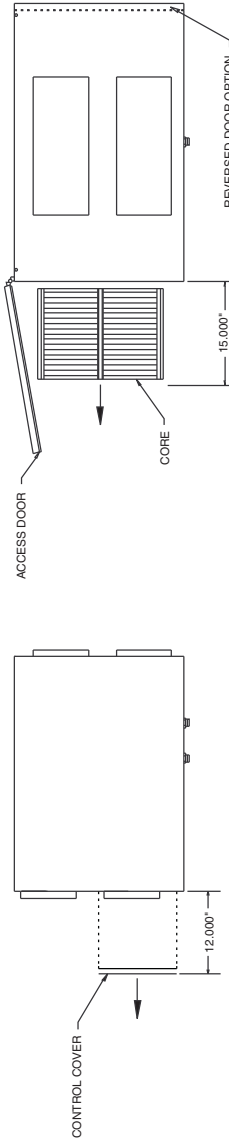

B12LC POLY CORE		B12LC ALUMINUM CORE		B12LC ERV-HM CORE	
PTS	LB.	PTS	LB.	PTS	LB.
A	54.02	A	60.41	A	57.84
B	38.98	B	43.59	B	41.68
C	54.02	C	60.41	C	57.92
D	38.98	D	43.59	D	41.68
<b>TOTAL</b>	<b>186.00</b>	<b>TOTAL</b>	<b>208.00</b>	<b>TOTAL</b>	<b>199.00</b>
					<b>92.41</b>

CONNECTION TABLE	
CONNECTION SIZES	
(A)	1/4 GAUGE WIRE NUT
(B)	CONDENSATE DRAIN FITTING (2X) 3/4" NPT

# Appendix B (cont'd)

## UNIT DIMENSIONS

### B-4: B12LC WITH RECIRCULATION MODULE (FACTORY INSTALLED)

B12LC POLY CORE with recirculation module			B12LC ALUMINUM CORE with recirculation module			B12LC ERV HW CORE with recirculation module		
P.T.S.	LB.	KG.	P.T.S.	LB.	KG.	P.T.S.	LB.	KG.
112	247		122	289		122	269	
TOTAL			TOTAL			TOTAL		

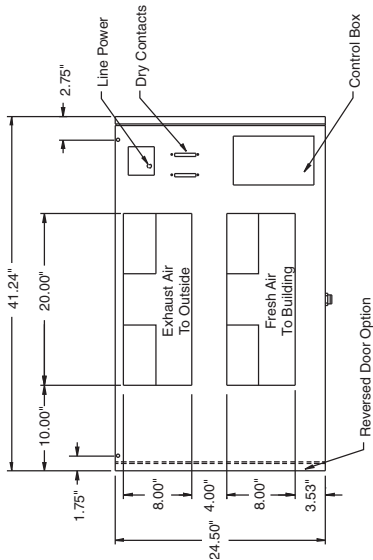
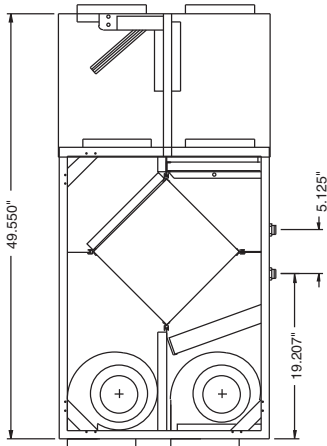
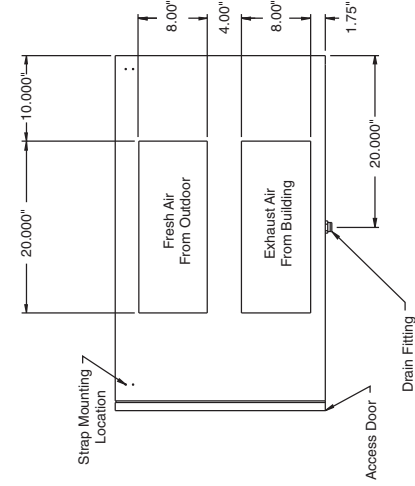

NOTE:  
For units with the reversed door option, interior components will appear as a mirror image of the above diagram.

A minimum of 15.00" clearance from any obstruction is required for removal of heat recovery cores, fans, etc.  
The access door can be removed from cabinet with only 2.00" of clearance.

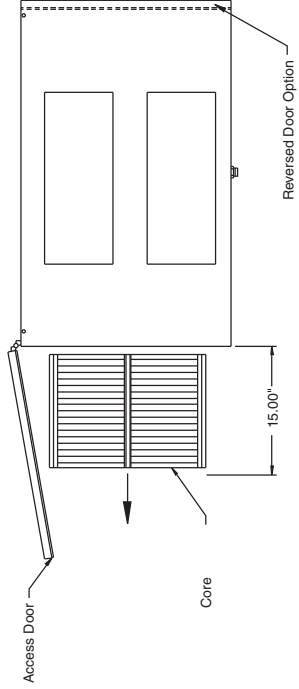

A minimum of 12.00" clearance from any obstruction is required for removal of control box.

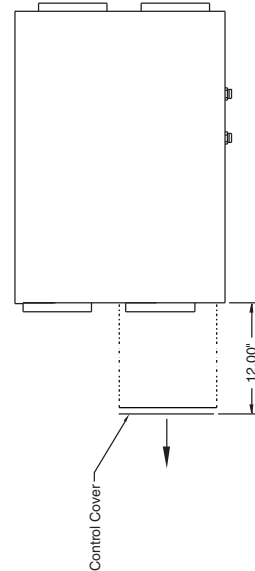



# Appendix B (cont'd)

## UNIT DIMENSIONS

### B-5: B1600705

**NOTES:**

-  Center of gravity
-  Direction of airflow

B1600705		
PTS	LB	Kg
A	32.74	14.85
B	68.46	31.05
C	35.20	15.97
D	73.60	33.38
<b>TOTAL</b>	<b>210.00</b>	<b>95.25</b>

CONNECTION TABLE	
CONNECTION SIZES	
(A)	1/4 gauge wire nut
(B)	Condensate drain fitting (2x) 3/4" NPT

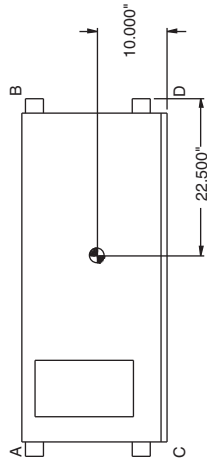

TOP

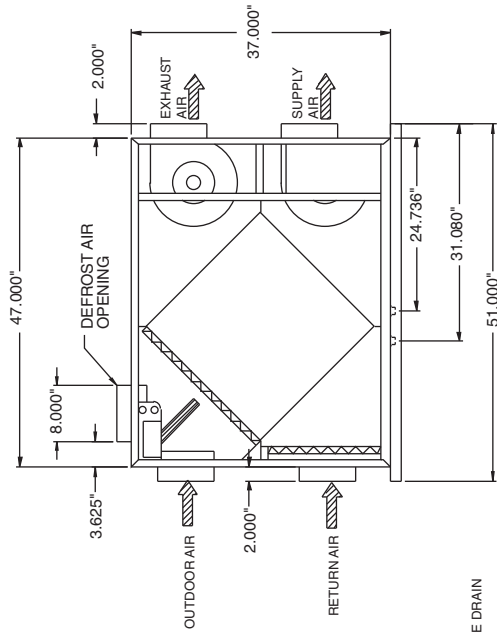

FRONT

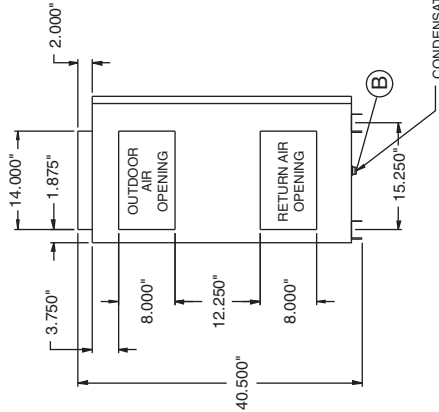

LEFT SIDE

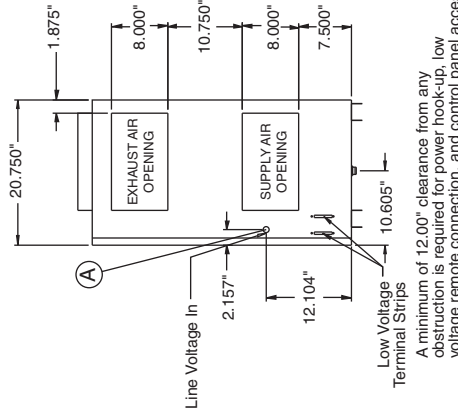

RIGHT SIDE

A minimum of 21.00" clearance from any obstruction is required for power hook-up, low voltage remote connection, and control panel access.

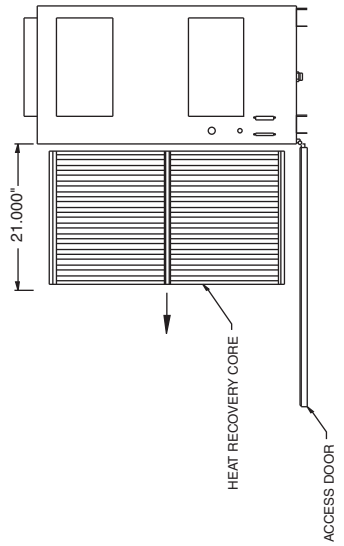

# Appendix C

## BALANCING DAMPERS POSITION

### B6LC AND B12LC

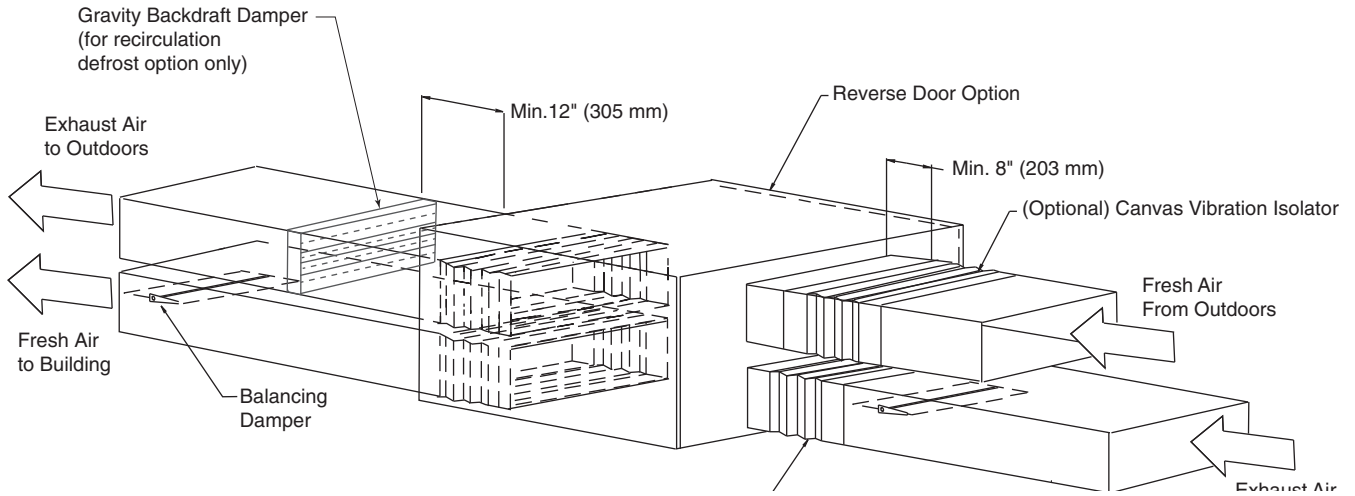

### B1600705

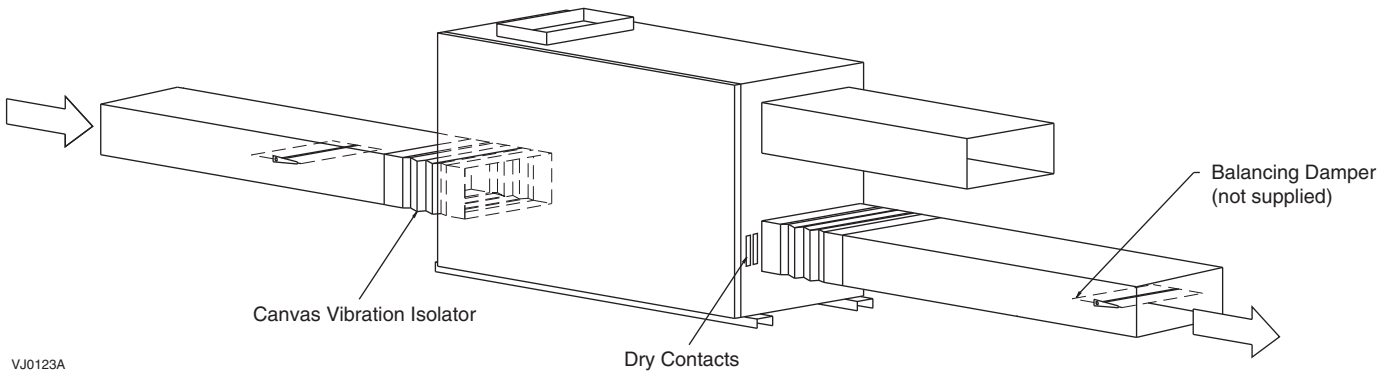

VJ0123A

# Appendix D

## DRAIN CONNECTIONS

### B6LC AND B12LC

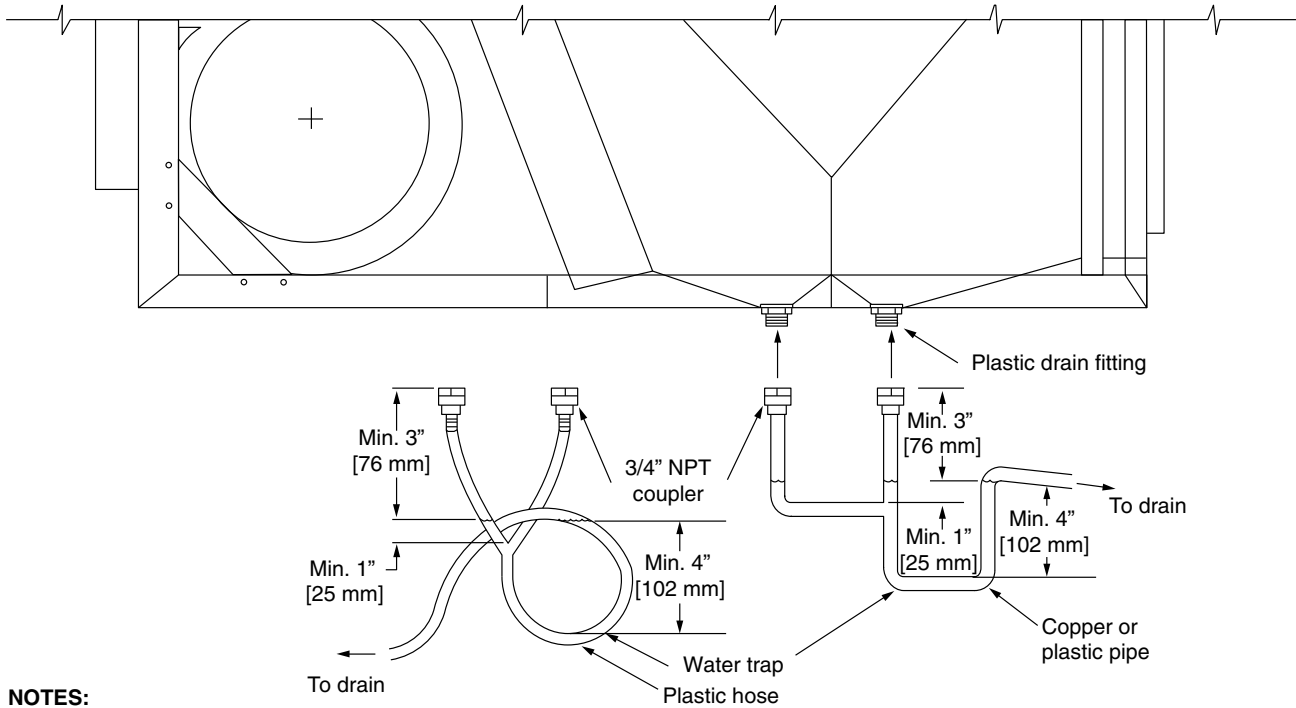

**NOTES:**

1. All hose, pipe and couplers to be supplied by others.
2. Slope drain lines minimum 1/4" per foot.

VO0002A

### B1600705

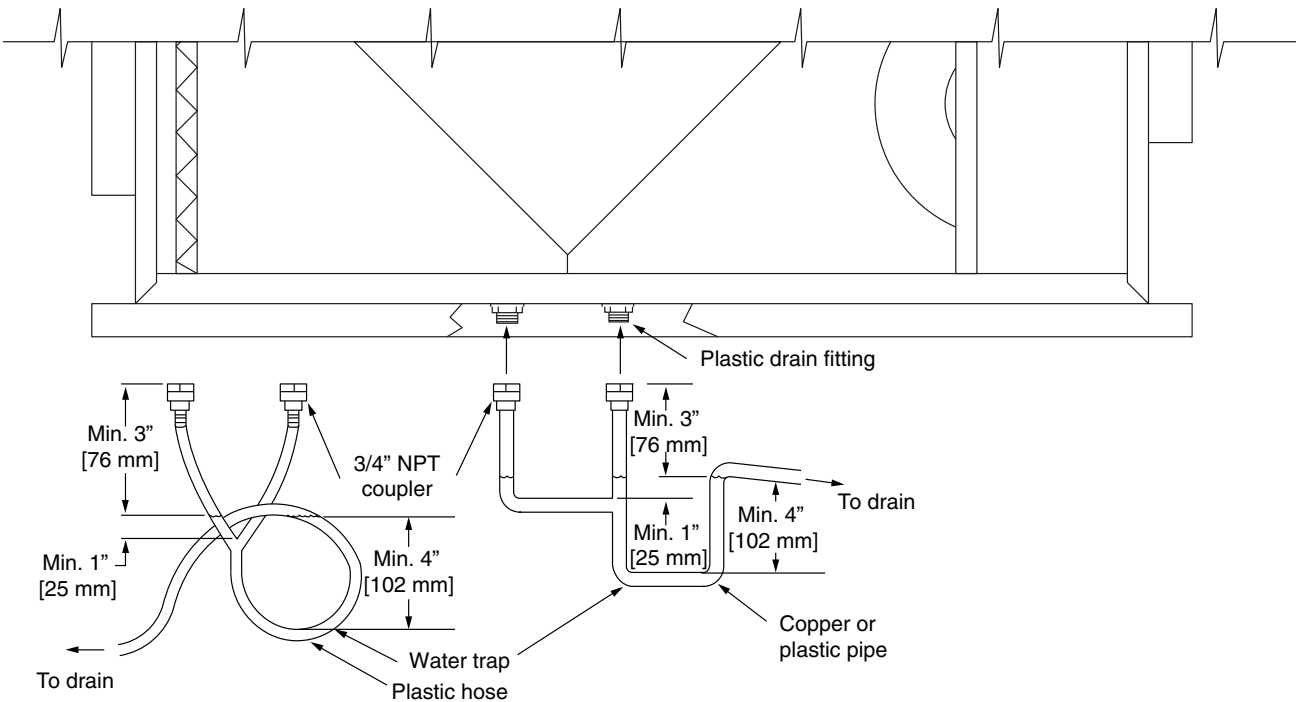

**NOTES:**

1. All hose, pipe and couplers to be supplied by others.
2. Slope drain lines minimum 1/4" per foot.

VO0001A



# Appendix E

## TERMINAL CONTROL DIAGRAMS

### E-1: TERMINAL LABEL

A low voltage remote control wiring interface is provided on the unit. The connections for the low voltage remote wiring are located on two terminals adjacent to the exhaust fan outlet (or adjacent to the supply fan outlet on the B1600705 unit). All field installed wiring must be low voltage class II.

#### REMOTE WALL CONTROL

Optional wall control requires a 4 wire LVT-24 gauge (or equivalent). This remote wall control runs on 12 VDC.

#### LOW VOLTAGE CONTROLS

All other terminals are dry contacts.

Low Voltage terminal control consists of the following:

#### WALL CONTROL

4 wire LVT 24 gauge minimum

#### OCCUPIED (NIGHT SET BACK) TIMER/SENSOR

24 VAC, needs dry contact

#### LOW - COM - HIGH

Remote fan switching requires a single pole, double throw switch (SPDT)

#### FAN INTERLOCK RELAY OUTPUT (FF)

Dry contact closes on ventilation or defrost. Used to control external fan.

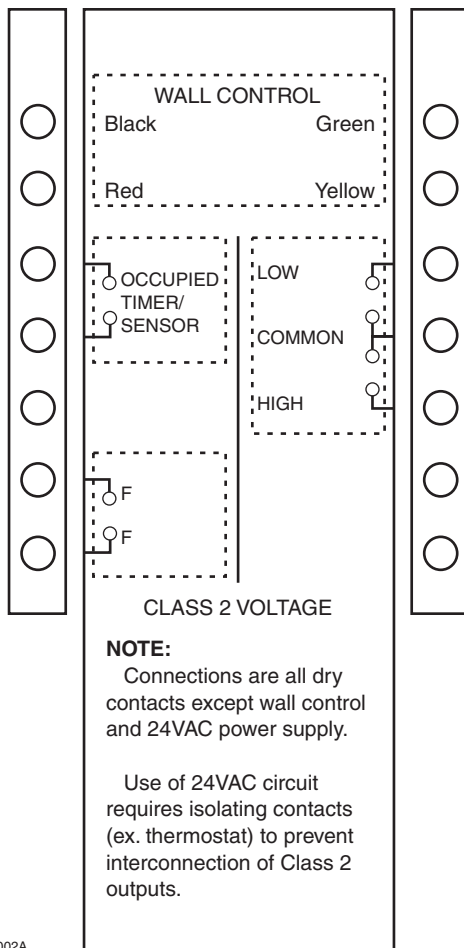

VE0002A

### E-2: WALL CONTROL CONNECTION

Two types of remote wall controls are available:

1. Slide Switch Wall Control with fan switch and dehumidistat control (for B6LC and 1B2LC units)
2. VT10W Wall Control with fan mode selection, dehumidistat control and high speed recirculation mode (for B1600705 unit).

The remote wall controls work with the microprocessor electronic control within the unit to control ventilation sequences. Each wall control has different features and require 4-wire connection to the unit as shown below.

Without the wall control, fans can be operated with a remote fan switch as shown in Appendix E-4.

#### NOTE:

When using a wall control, never use the the LOW, COMMON and HIGH terminals.

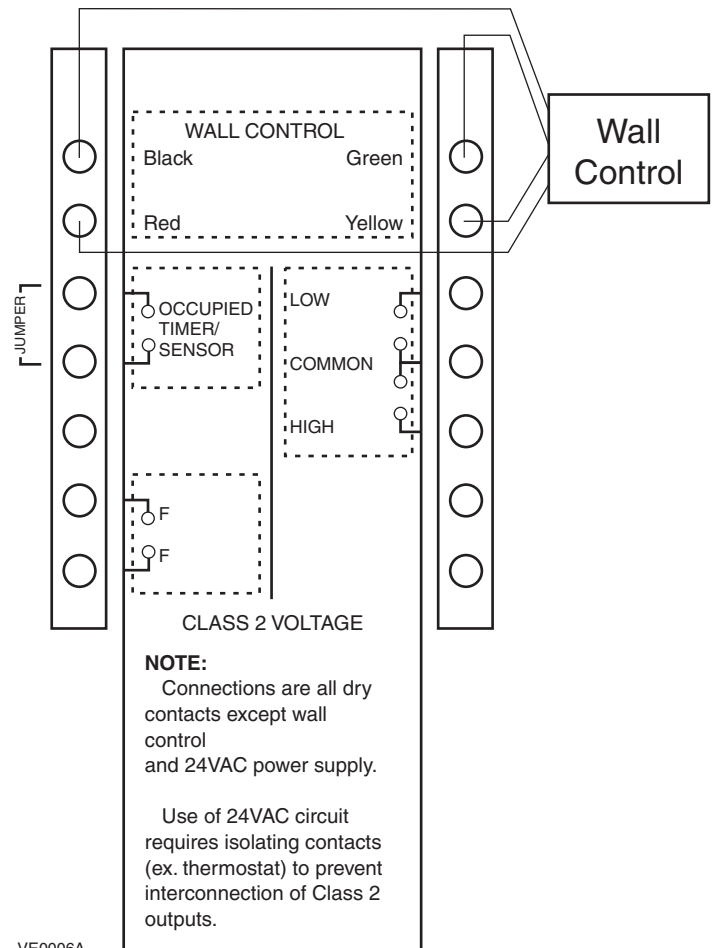

VE0006A

# Appendix E (cont'd)

## TERMINAL CONTROL DIAGRAMS

### E-3: OCCUPIED TIMER/SENSOR CONNECTION (NOT SOLD BY BROAN)

Occupancy control is achieved by connection to the terminal interface shown below. These terminals require a dry contact which could be provided by a number of types of controls such as a timer, light sensor, occupancy sensor, building management system, or other. **The unit will not operate unless these contacts are closed!!**

The illustration below shows a factory installed jumper and programmable timer option (supplied by others).

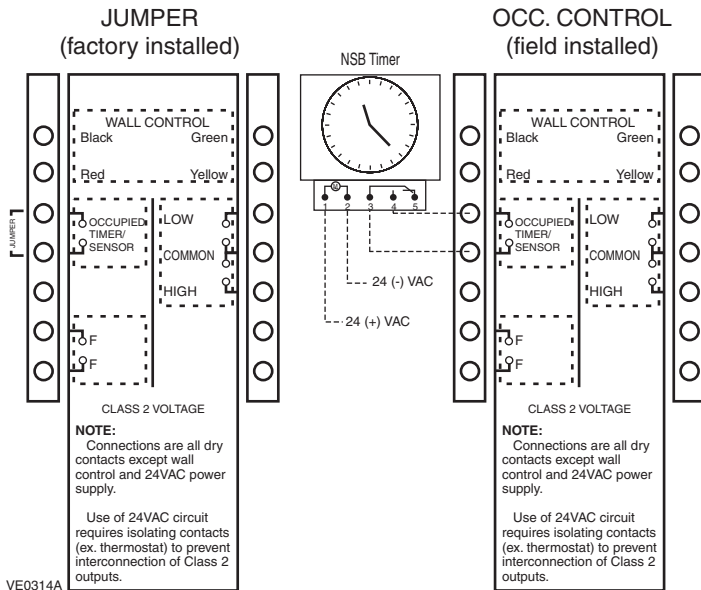

### E-4: REMOTE FAN CONTROL

Remote fan control can be achieved by connecting dry contact controls to the terminal interface at terminals labeled: LOW - COM - HIGH.

These controls could be the following: SPDT switch, dehumidistat, CO<sub>2</sub> sensor, light sensor, timer, building management system, etc., supplied by others.

The illustration below represents a switch connected to the unit.

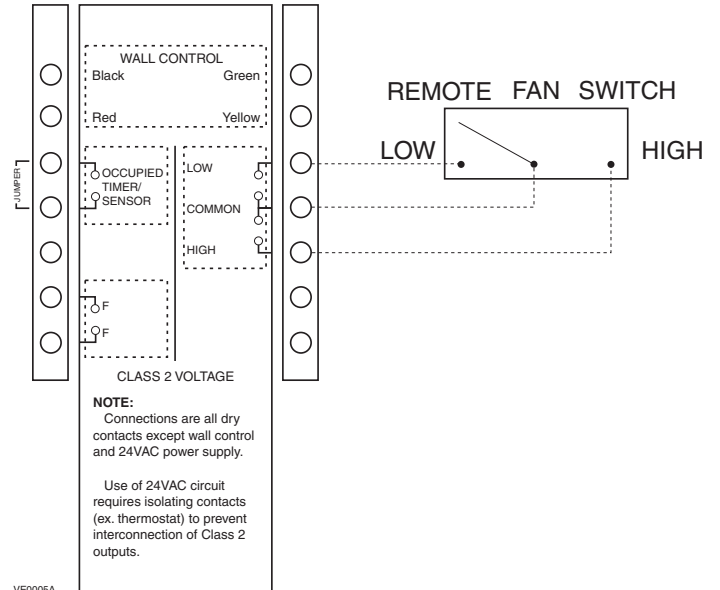

# Appendix F

## CONTROL BOX ASSEMBLY B6LC AND B12LC

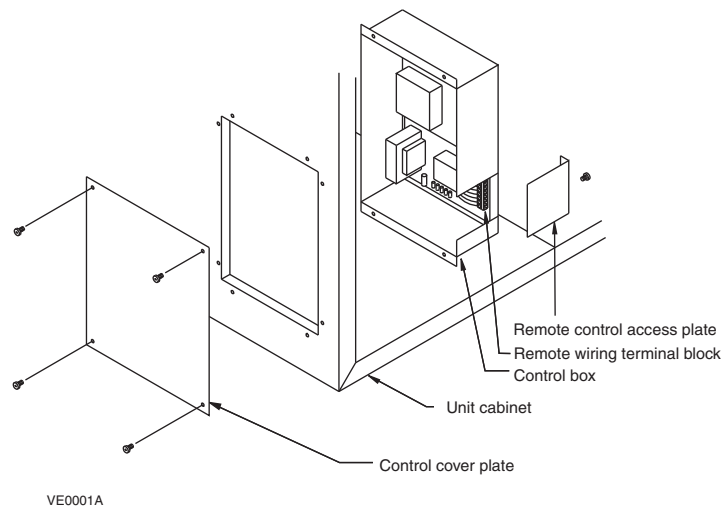

# Appendix G

## MAKE-UP HEAT REQUIREMENTS

### B6LC AND B1600705

Although the B6LC, B1600705 and B12LC models have good efficiencies, the supply air could be colder than the ambient room air. It is possible to eliminate the discomfort associated with this temperature difference by installing an electric duct heater. This will temper the air before it is distributed throughout the building. The tables below gives the heating requirements at different temperatures and airflows.

**NOTE:**

The data does not reflect a reduction in effectiveness due to frosting.

Based on the standard air at: 1.2 Kg/m<sup>3</sup> and Cp = 1.0 KJ/Kg°C

13.35 lb/ft<sup>3</sup> and Cp = .24 Btu/lbm°F

B6LC and B1600705 UNITS		Outdoor Air -40°F			Outdoor Air -22°F			Outdoor Air -4°F			Outdoor Air 14°F			Outdoor Air 32°F		
		Desired Air Temperature			Desired Air Temperature			Desired Air Temperature			Desired Air Temperature			Desired Air Temperature		
Supply Air (CFM)	Supply Air (L/s)	55°F	68°F	73°F	55°F	68°F	73°F	55°F	68°F	73°F	55°F	68°F	73°F	55°F	68°F	73°F
700	330	7.4	10.4	11.5	5.6	8.6	9.7	3.9	6.8	8.0	2.1	5.1	6.2	0.3	3.3	4.4
650	307	6.6	9.4	10.5	5.0	7.8	8.9	3.4	6.2	7.3	1.8	4.6	5.6	0.2	3.0	4.0
600	283	5.9	8.5	9.4	4.5	7.0	8.0	3.0	5.6	6.5	1.6	4.1	5.1	0.1	2.7	3.7
550	259	5.2	7.6	8.5	3.9	6.3	7.2	2.6	5.0	5.9	1.3	3.7	4.6	0.1	2.4	3.3
500	236	4.0	6.1	7.0	3.0	5.1	5.9	1.9	4.0	4.9	0.9	3.0	3.8	-	1.9	2.7
450	212	3.0	4.9	5.6	2.1	4.0	4.8	1.3	3.2	3.9	0.4	2.3	3.1	-	1.5	2.2
400	189	2.2	3.9	4.6	1.5	3.2	3.9	0.9	2.5	3.2	0.2	1.9	2.5	-	1.2	1.8

# Appendix G

## MAKE-UP HEAT REQUIREMENTS

### B12LC

B12LC UNIT		Outdoor Air -40°F			Outdoor Air -22°F			Outdoor Air -4°F			Outdoor Air 14°F			Outdoor Air 32°F		
		Desired Air Temperature			Desired Air Temperature			Desired Air Temperature			Desired Air Temperature			Desired Air Temperature		
Supply Air (CFM)	Supply Air (L/s)	55°F	68°F	73°F	55°F	68°F	73°F	55°F	68°F	73°F	55°F	68°F	73°F	55°F	68°F	73°F
1250	590	14.6	19.9	21.9	11.2	16.5	18.5	7.8	13.1	15.2	4.4	9.7	11.8	1.0	6.3	8.4
1200	566	13.5	18.6	20.6	10.4	15.5	17.4	7.2	12.3	14.3	4.0	9.1	11.1	0.8	5.9	7.9
1150	542	12.6	17.4	19.3	9.6	14.5	16.4	6.6	11.5	13.4	3.6	8.5	10.4	0.7	5.5	7.4
1100	519	11.2	15.9	17.7	8.5	13.2	15.0	5.8	10.5	12.3	3.1	7.7	9.6	0.4	5.0	6.8
1050	495	10.7	15.2	16.9	8.1	12.6	14.3	5.5	10.0	11.7	2.9	7.4	9.1	0.4	4.8	6.5
1000	472	9.9	14.1	15.7	7.4	11.7	13.3	5.0	9.3	10.9	2.6	6.9	8.5	0.2	4.4	6.1
900	425	8.5	12.4	13.8	6.4	10.2	11.7	4.3	8.1	9.6	2.2	6.0	7.5	0.1	3.9	5.4
800	377	7.0	10.4	11.7	5.2	8.6	9.9	3.4	6.8	8.2	1.7	5.0	6.4	-	3.3	4.6
700	330	5.1	8.1	9.3	3.7	6.7	7.9	2.3	5.3	6.5	0.9	3.9	5.1	-	2.5	3.7

Although the B6LC, B1600705 and B12LC models have good efficiencies, the supply air could be colder than the ambient room air. It is possible to eliminate the discomfort associated with this temperature difference by installing an electric duct heater. This will temper the air before it is distributed throughout the building. The tables below gives the heating requirements at different temperatures and airflows.

**NOTE:**

The data does not reflect a reduction in effectiveness due to frosting.

Based on the standard air at: 1.2 Kg/m<sup>3</sup> and Cp = 1.0 KJ/Kg°C

13.35 lb/ft<sup>3</sup> and Cp = .24 Btu/lbm°F

# Appendix H

## WIRING DIAGRAMS

### B6LC & B12LC - Exhaust Defrost - Normal Low Speed

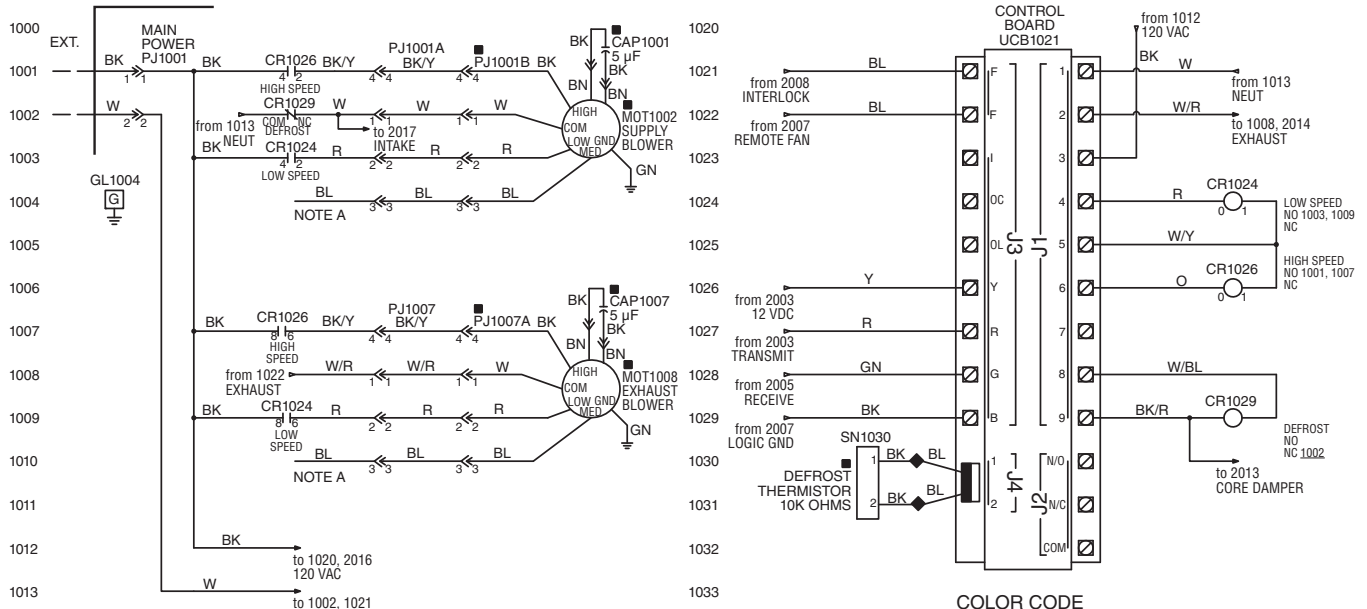

NOTE A: THE MEDIUM SPEED WIRES MAY OPTIONALLY REPLACE THE LOW SPEED (RED) WIRES RUNNING FROM RELAY LOW SPEED.

--- FIELD WIRING (USE COPPER CONDUCTORS ONLY)  
 ■ UNIT ASSEMBLY (NOT ON CONTROL PANEL)

COLOR CODE			
BK	BLACK	R	RED
BK/R	BLACK/RED	W	WHITE
BK/Y	BLACK/YELLOW	W/BL	WHITE/BLUE
BL	BLUE	W/R	WHITE/RED
BN	BROWN	W/Y	WHITE/YELLOW
GN	GREEN	Y	YELLOW
O	ORANGE		

#### CONTROL BOX BOM

TAGS	QTY.	DESCRIPTION
CR1029	1	RELAY SPDT 120 VAC 1 HP 30 A @ 120 VAC
CR1024	2	RELAY DPST 120 VAC 1 HP 30 A @ 120 VAC
UCB1021	1	PC BOARD

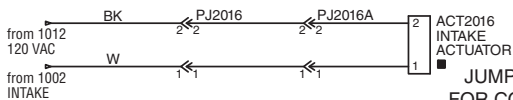
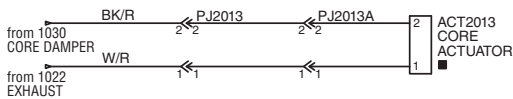
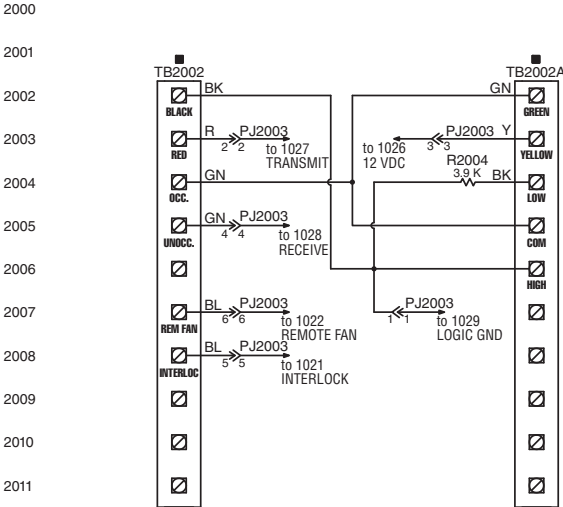

#### JUMPER SETTINGS FOR CONTROL BOARD

JU1	A	OFF
JU1	B	OFF
JU1	C	OFF
JU1	D	ON
JU1	E	ON
JU1	F	ON
JU1	G	ON

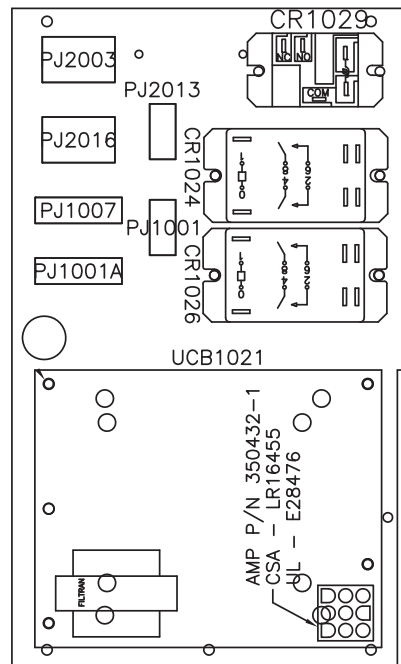



# Appendix H (cont'd)

## WIRING DIAGRAMS

### B6LC & B12LC - Recirculation Defrost - Normal Low Speed

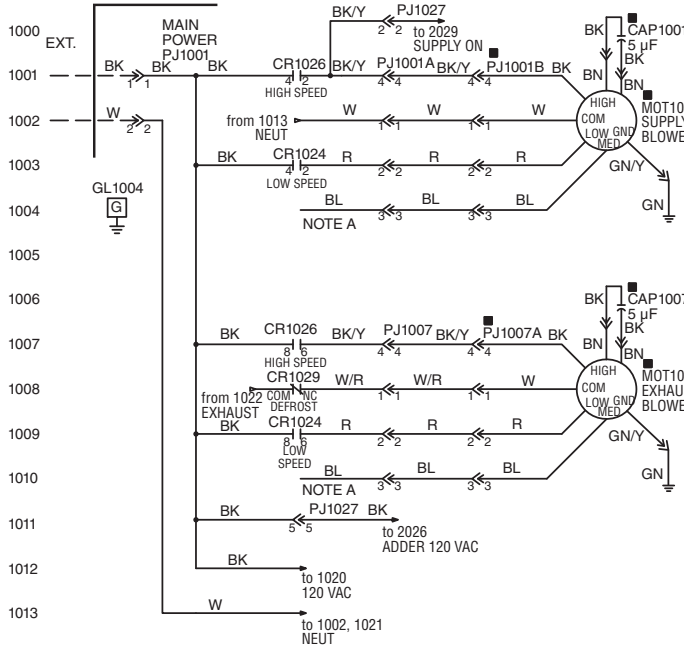

NOTE A: THE MEDIUM SPEED WIRES MAY OPTIONALLY REPLACE THE LOW SPEED (RED) WIRES RUNNING FROM RELAY LOW SPEED.

--- FIELD WIRING (USE COPPER CONDUCTORS ONLY)  
 ■ UNIT ASSEMBLY (NOT ON CONTROL PANEL)

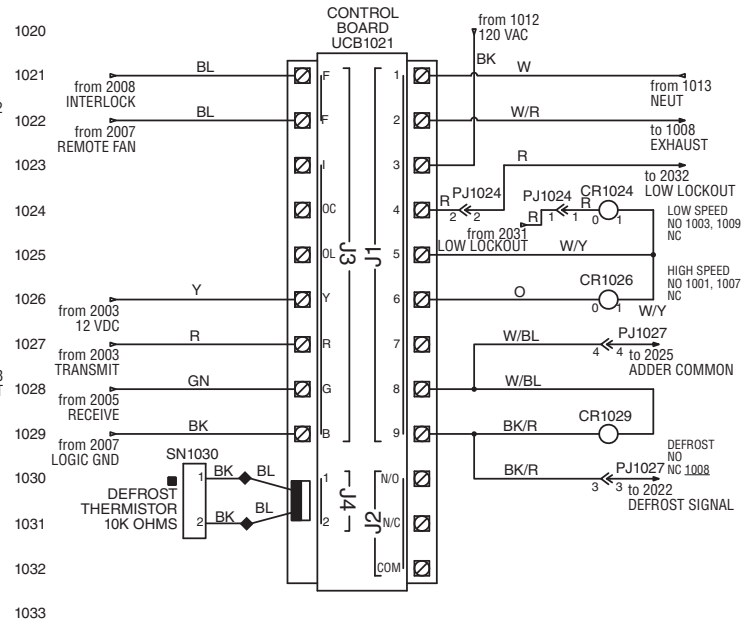

#### COLOR CODE

BK	BLACK	O	ORANGE
BK/R	BLACK/RED	R	RED
BK/Y	BLACK/YELLOW	W	WHITE
BL	BLUE	W/BL	WHITE/BLUE
BN	BROWN	W/R	WHITE/RED
GN	GREEN	W/Y	WHITE/YELLOW
GN/Y	GREEN/YELLOW	Y	YELLOW

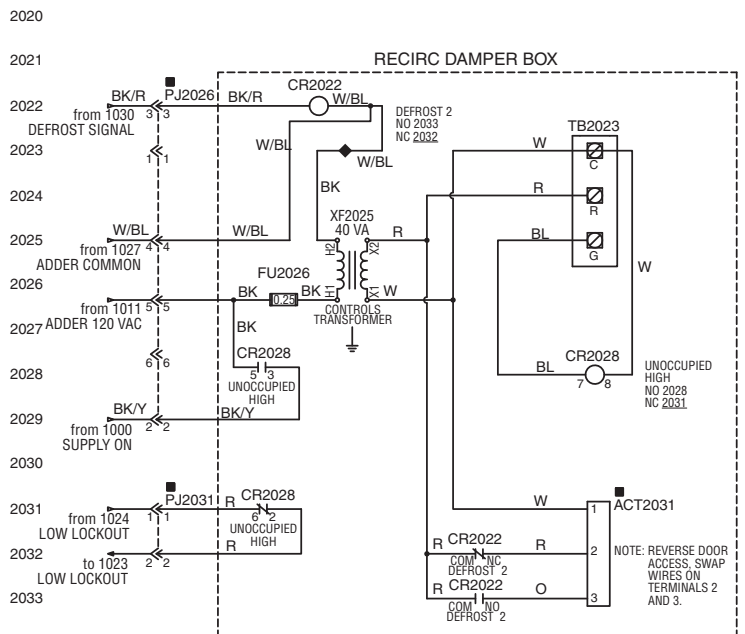
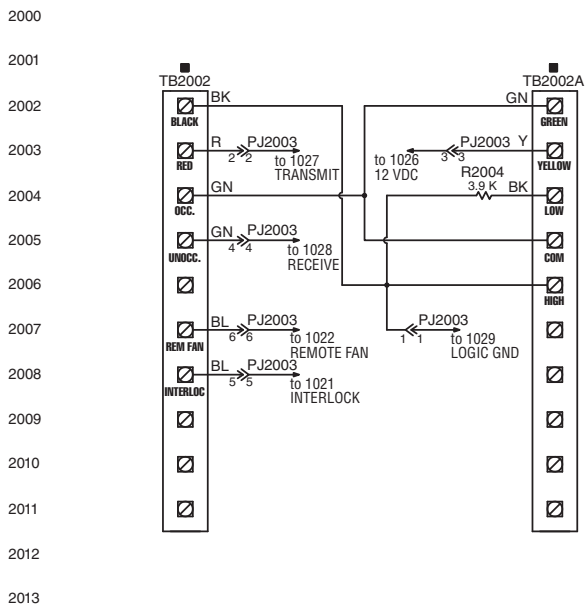

# Appendix H (cont'd)

## WIRING DIAGRAMS

### B6LC & B12LC - Recirculation Defrost - Normal Low Speed (cont'd)

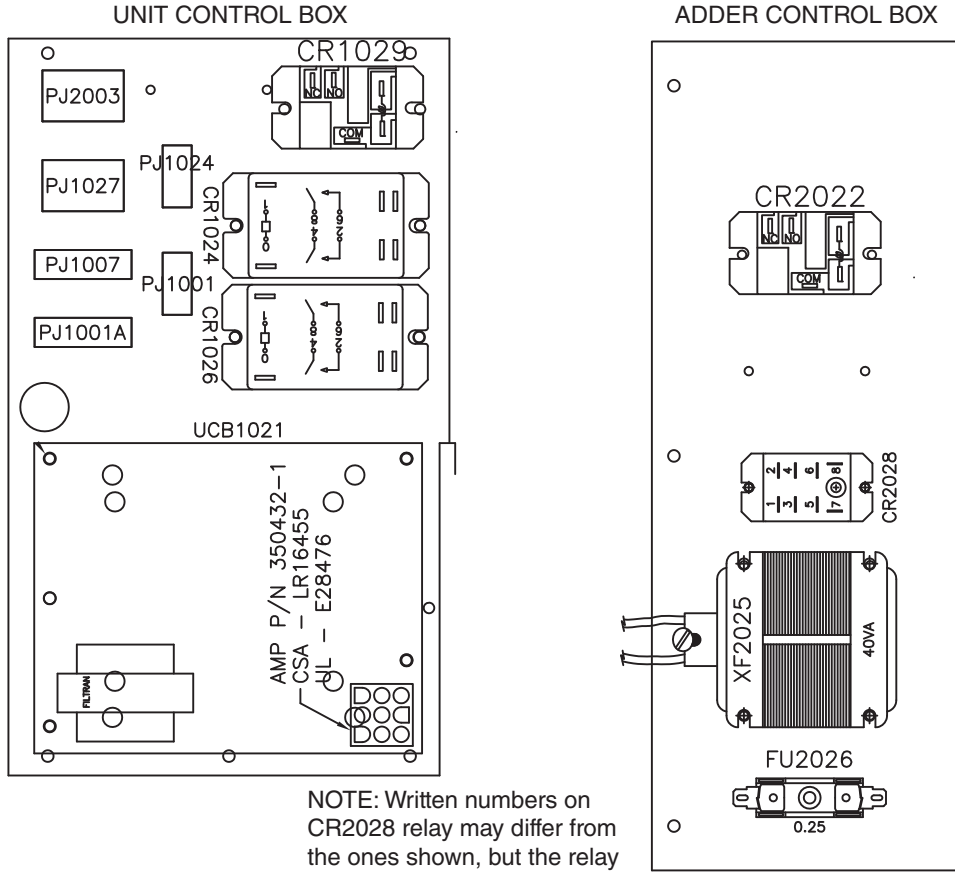

NOTE: Written numbers on CR2028 relay may differ from the ones shown, but the relay orientation must be the same as illustrated.

JUMPER SETTINGS FOR CONTROL BOARD

JU1	Setting	State
JU1	A	OFF
JU1	B	OFF
JU1	C	OFF
JU1	D	ON
JU1	E	ON
JU1	F	ON
JU1	G	ON

CONTROL BOX BOM

TAGS	QTY.	DESCRIPTION
CR1029	2	RELAY SPDT 120 VAC 1 HP 30 A @ 120 VAC
CR2022		
CR1024	2	RELAY DPST 120 VAC 1 HP 30 A @ 120 VAC
CR1026		
CR2028	1	RELAY DPDT 24 VAC 1/2 HP 15 A @ 120 VAC
FU2026	1	FUSE 0.25 A AND FUSE HOLDER MINI
UCB1021	1	PC BOARD
XF2025	1	TRANSFORMER

VE0365A

# Appendix H (cont'd)

## WIRING DIAGRAMS

### B1600705 - Recirculation Defrost

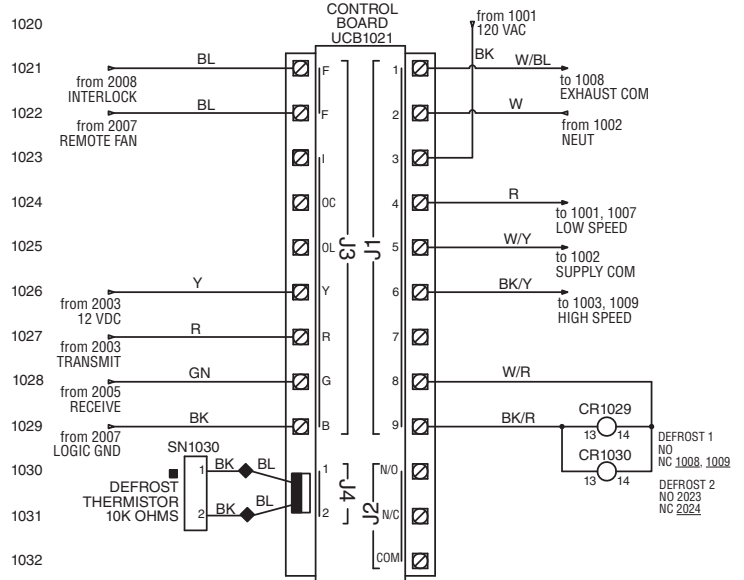
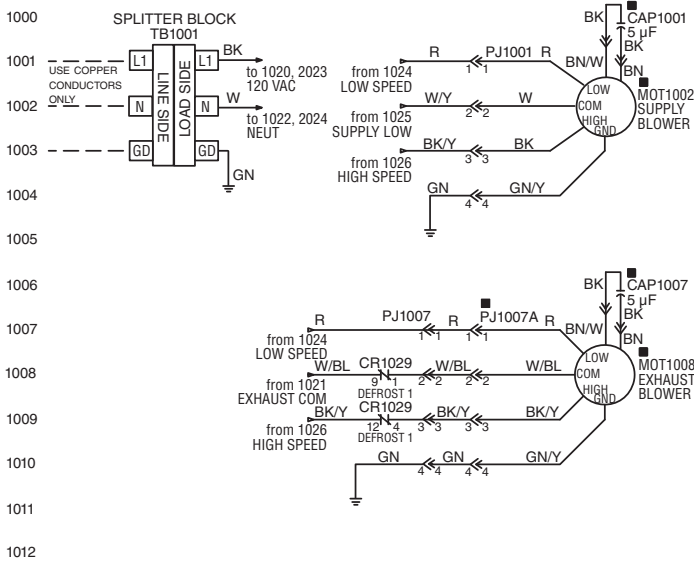

#### COLOR CODE

BK	BLACK	O	ORANGE
BK/R	BLACK/RED	R	RED
BK/Y	BLACK/YELLOW	W	WHITE
BL	BLUE	W/BL	WHITE/BLUE
BN/W	BROWN/WHITE	W/R	WHITE/RED
GN	GREEN	W/Y	WHITE/YELLOW
GN/Y	GREEN/YELLOW	Y	YELLOW

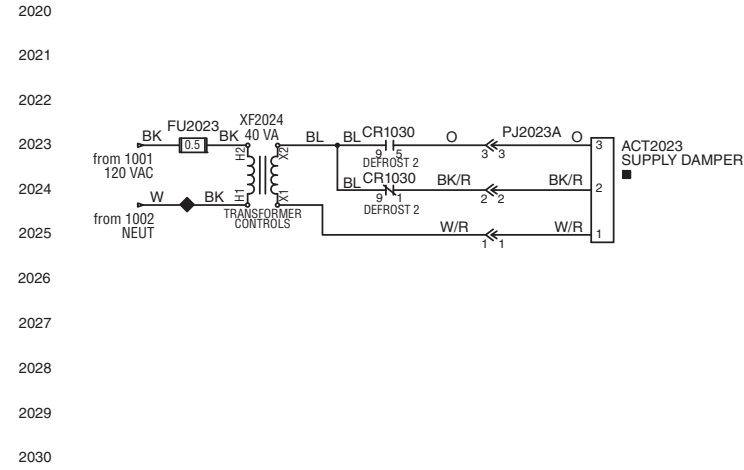
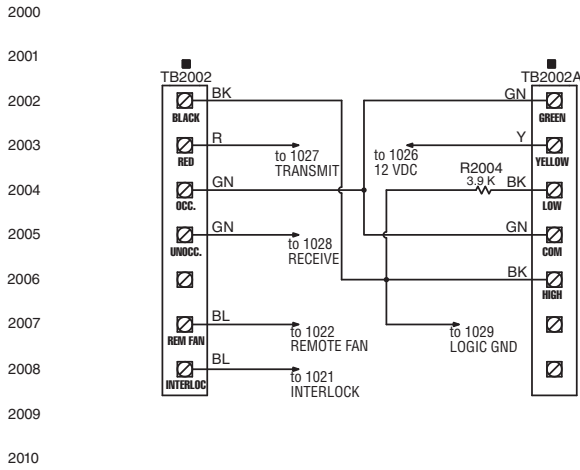

VE0368A

# Appendix H (cont'd)

## WIRING DIAGRAMS

### B1600705 - Recirculation Defrost (cont'd)

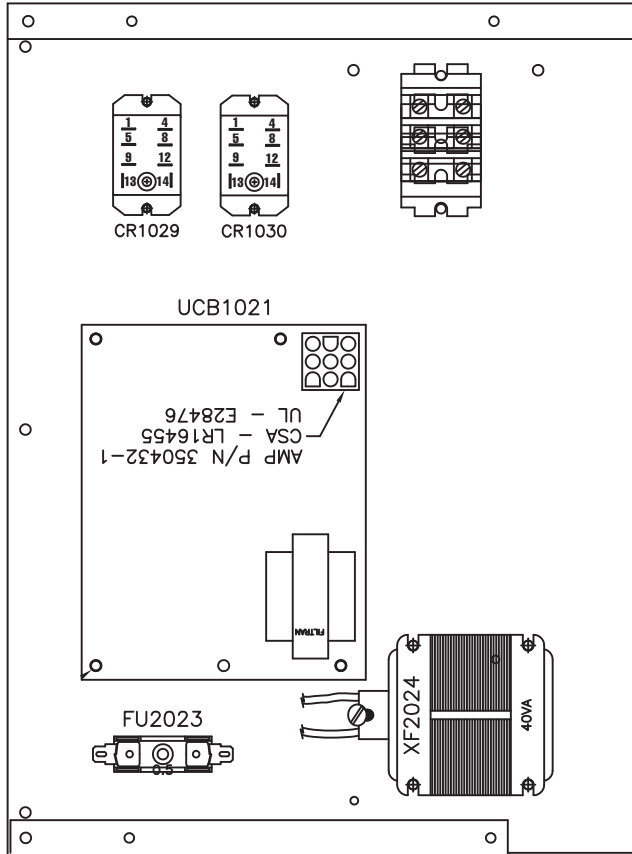

VE0369A

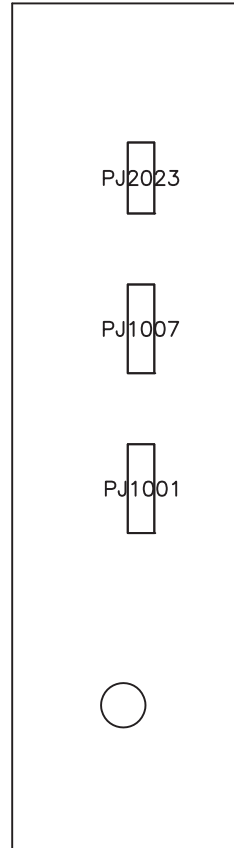

#### CONTROL BOX BOM

TAGS	QTY.	DESCRIPTION
CR1029	2	RELAY DPDT 120 VAC 1/2 HP
CR1030		15 A @ 120 VAC
FU2023	1	FUSE 0.5 A AND FUSE HOLDER FLUSH MOUNT
UCB1021	1	PC BOARD
XF2024	1	TRANSFORMER
R2004	1	RESISTOR 3.9K
SN1030	1	THERMISTOR 10K OHMS
TB1001	1	SPLITTER BLOCK

NOTE: Written numbers on CR1029 and CR1030 relays may differ from the ones shown, but the orientation of the relays must be the same as illustrated.

#### JUMPER SETTINGS FOR CONTROL BOARD

JU1	A	ON
JU1	B	OFF
JU1	C	OFF
JU1	D	ON
JU1	E	ON
JU1	F	ON
JU1	G	ON

# Appendix I

## TROUBLESHOOTING

SYMPTOMS	POSSIBLE CAUSES	SOLUTIONS
Inside air is too dry	Over ventilation - speed setting too high Dehumidistat setting is too low	Adjust speed setting Set dehumidistat control in a higher position (if applicable)
Persistent condensation on windows, walls, ceilings, etc.	Improper adjustment of dehumidistat control Improper ventilation rate Window frame is too cold or leaky	Adjust dehumidistat control knob to a lower setting Install a dehumidistat (option) Repair window frame
Unit stops functioning	Electrical supply interrupted	Check the unit circuit breaker
Air from supply diffusers too cold	Imbalance of supply and exhaust air  Outdoor temperature very cold	Check filters and cores for blockage Check balance of airflows Install electric duct heater if necessary
Unit makes annoying noise	Blower wheel out of alignment	Remove the motor/blower assembly and adjust blower wheel
Core freezing up	Imbalance of supply and exhaust air  Defrost damper not functioning	Check filters and cores for blockage Check balance of airflows Check for operation of both defrost damper actuators

For technical assistance and warranty information, please call your local supplier.

# Appendix I

## TROUBLESHOOTING

SYMPTOMS	POSSIBLE CAUSES	SOLUTIONS
Inside air is too dry	Over ventilation - speed setting too high Dehumidistat setting is too low	Adjust speed setting Set dehumidistat control in a higher position (if applicable)
Persistent condensation on windows, walls, ceilings, etc.	Improper adjustment of dehumidistat control Improper ventilation rate Window frame is too cold or leaky	Adjust dehumidistat control knob to a lower setting Install a dehumidistat (option) Repair window frame
Unit stops functioning	Electrical supply interrupted	Check the unit circuit breaker
Air from supply diffusers too cold	Imbalance of supply and exhaust air  Outdoor temperature very cold	Check filters and cores for blockage Check balance of airflows Install electric duct heater if necessary
Unit makes annoying noise	Blower wheel out of alignment	Remove the motor/blower assembly and adjust blower wheel
Core freezing up	Imbalance of supply and exhaust air  Defrost damper not functioning	Check filters and cores for blockage Check balance of airflows Check for operation of both defrost damper actuators

For technical assistance and warranty information,  
please call your local supplier.